

WAGATE®

WaGate Flap Valve

KKL NPS 8"-63"
With wall flange

Use

Used as flood protection and emergency shutdown.
Prevents backflow. For stormwater and waste water.

- Mounted against a flat surface
- Can be mounted below the water surface
- The flap has a 15 degree inclination
- Corrosion-proof material
- UV-resistant



Material

Valve body: PEHD
Hinges and flaps: EN 1.4404
Sealing against flap: EPDM
Steel: EN 1.4404

Technical data

Waterproof for one-head sealing
Max pressure: 0,5 psi
Temperature: -50°C - +80°C

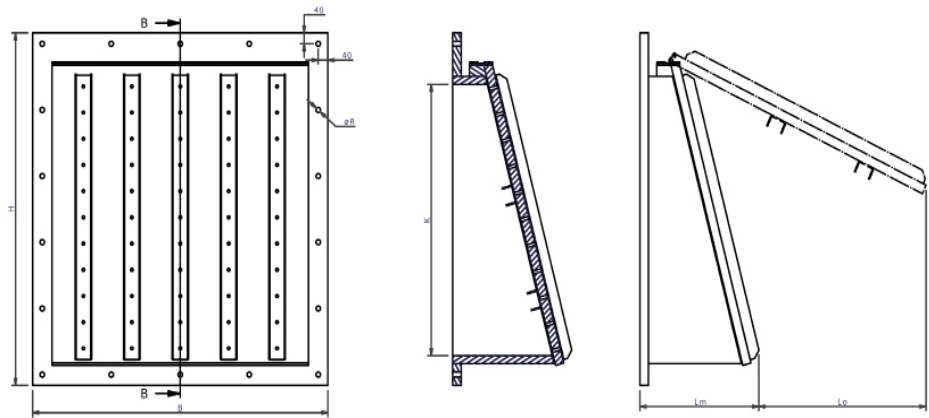

Dimensions [in] and weight [lbs]

NPS	H	B	Ør	L	Lt	Weight	Ho
8	19,7	15,5	8 x Ø18	9,2	16,8	33	14,4
16	31,5	24,4	8 x Ø18	12,2	24,2	88	18,3
20	31,5	28,4	8 x Ø18	13,4	28	121	20,3
25	36,6	33,4	20 x Ø18	15,3	31,5	198	22,8
28	39,8	36,6	16 x Ø18	16,1	35,8	243	24,4
32	43,3	40,1	20 x Ø18	16,9	39	298	26,2
35	47,2	44,1	20 x Ø18	17,7	41,3	353	28,2
39	51,2	48	18 x Ø18	19,3	46,5	452	30,1
43	55,1	52	20 x Ø18	20,5	50,4	507	32,1
47	59,1	55,9	20 x Ø18	21,5	53,9	606	34,1
55	64,8	63	32 x Ø18	25,4	63	816	36,9
59	68,7	66,9	32 x Ø18	26,5	66,5	904	38,9
63	72,6	70,9	36 x Ø18	27,4	70,3	992	40,8

Other dimensions depending on purpose.
The right to design changes is reserved.

150 North Michigan Ave
Chicago, IL 60601
+1 888-927-8677

WARPRO®