

## WaGate Sluice Gate

SPM-P-TG NPS 28" - 56"

Sealed for two-sided pressure

### Area of use

Used for regulating or shutting down flow for wastewater, stormwater, process water and sludge. For use in industrial facilities, agriculture and aquaculture.

- Compact unit, self-supporting frame design
- Non-rising spindle
- Operated manually. Can be customized with electric, pneumatic or hydraulic actuators
- Can be customized with pipe protrusion for penetration through chamber wall
- Also available with curved flange



### Material

Frame: EN 1.4404 ( EN 1.4462)

Damper plate: EN 1.4404 ( EN 1.4462)

Spindle: EN 1.4571, (EN 1.4462)

Spindle nut: Zinc-free bronze

Sluice Gate body: EPDM

Seal according to: DIN 19569-4

### Accessory

Wall seal: EPDM cellular rubber

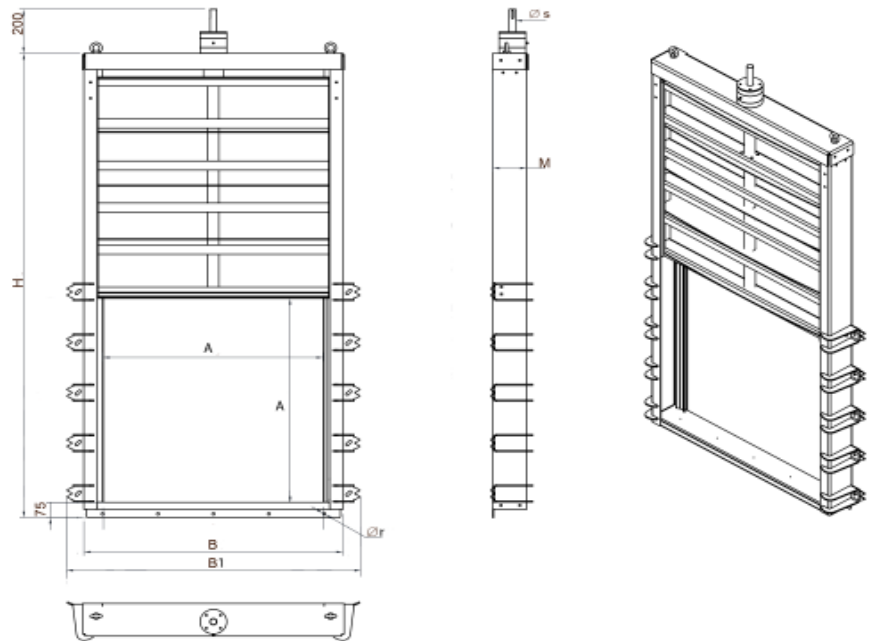

### Dimensions [in] and weight [lbs]

NPS	A	H	B	B1	Ør	Øs	M	Nm	Turns to open	Weight	mWc
28	27,95	66,73	34,65	40,59	0.59 x Ø0,51	0.98	6	0,98	142	277,8	6
32	31,50	73,82	38,19	44,13	0.75 x Ø0,51	0.98	6	1,38	160	319,7	6
40	39,37	89,57	46,06	52,01	0.91 x Ø0,51	0.98	6	2,56	167	407,9	6
48	47,24	105,31	53,94	59,88	0.98 x Ø0,51	1.18	6	3,54	200	509,3	6
56	55,12	121,06	61,81	67,76	1.14 x Ø0,51	1.18	6	5,51	234	595,2	6