

WaGate Sluice Gate

SPS-TL/RTL NPS 8" - 24"
Sealed for one-sided pressure

Use

Used for regulating or shutting down flow for wastewater, stormwater, process water and sludge. For use in industrial facilities, agriculture and aquaculture.

- Pushed/operated by hand
- Can be customised with pipe pup piece for penetration through well wall
- Also available with domed flange



Material

Frame: EN 1.4404 (EN 1.4462)
Louvred gate: EN 1.4404 (EN 1.4462)
Spindle: EN 1.4571, (EN 1.4462)
Spindle nut: Zinc-free bronze
Facing louvred gate: EPDM
Seal according to: DIN 19569-4

Accessory

Seal with wall: EPDM cellular rubber

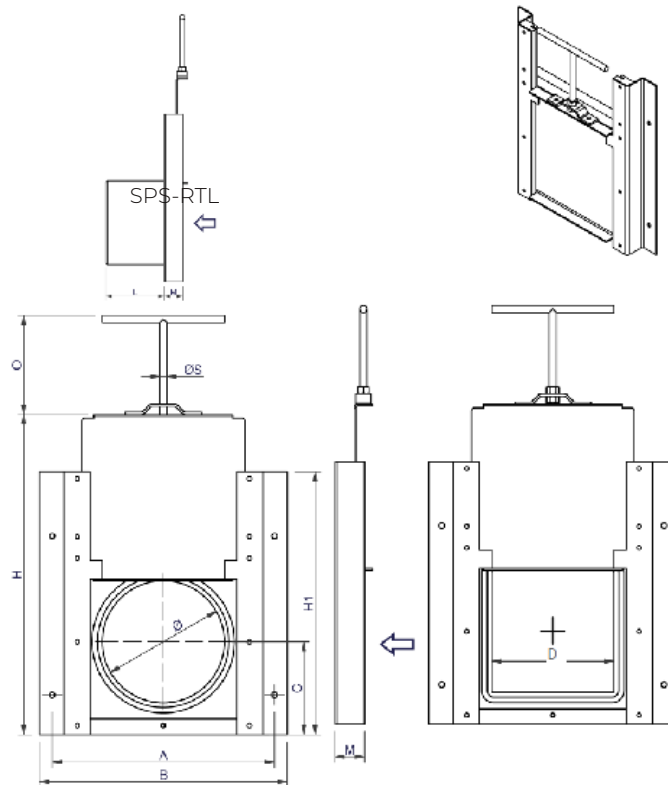

Dimensions [in] and weight [lbs]

NPS	Ø	D	A	B	C	H	H1	L	M	O	ØS	Weight	mWc
8	8	8x8	14,33	15,98	5,98	20,63	17,09	> 6,89	1,9	5,91	0,47	17,6	4
10	10	10x10	16,30	17,95	6,97	24,57	19,06	> 7,87	1,9	5,91	0,47	22,0	4
12	14	14x14	18,86	20,51	8,27	29,69	21,65	> 9,84	1,9	5,91	0,47	26,5	4
16	16	16x16	22,20	23,86	9,92	36,38	24,96	> 11,81	1,9	7,87	0,63	35,3	4
20	20	20x20	26,14	27,80	11,89	44,25	28,82	> 14,76	1,9	7,87	0,63	46,3	2
24	25	25x25	31,26	32,91	14,37	54,49	33,86	> 18,70	1,9	7,87	0,63	59,5	2