

Rev	Note	CreatedBy	Appr.By	Appr.Date
A		PM	AE	2020-08-25

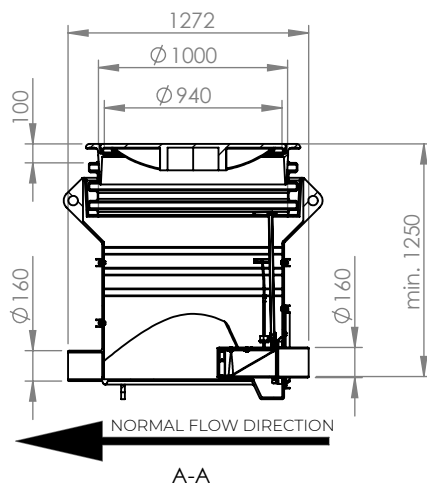

Alternativ 1:

- DN1000 Stigarrör m. betäckning
- min. VG-FM 1250mm

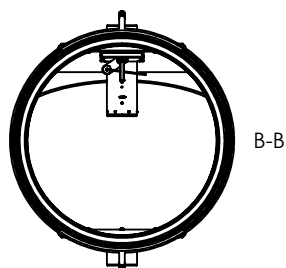
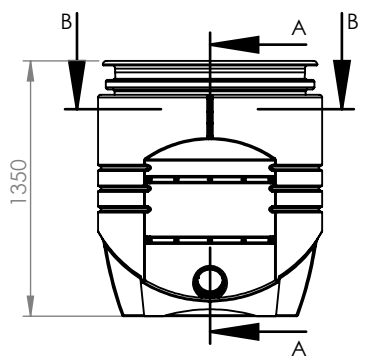
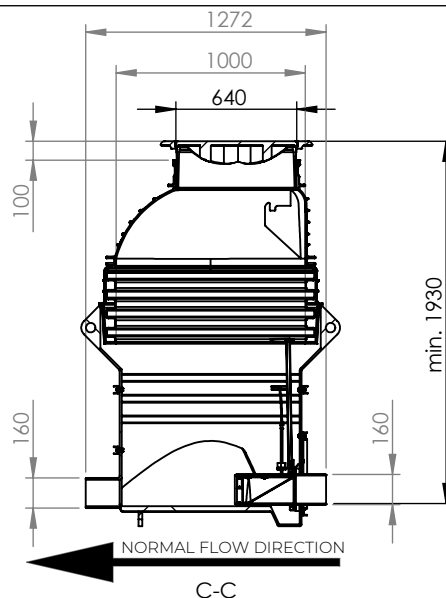
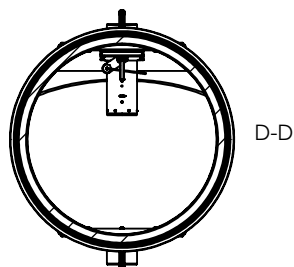
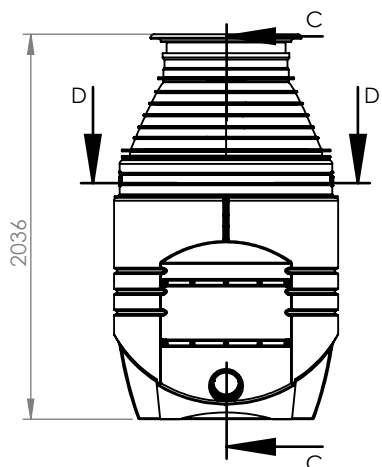

Alternativ 2:

- DN1000 stigarrör m. kona och betäckning
- min. VG-FM 1930mm

© 2018 Wapro AB. This document is subject to copyrights owned by Wapro AB. Any amendments, republication, retransmission, and/or reproduction of all or any part of the document is expressly prohibited, unless the copyright owner of the material has expressly granted its prior written consent. All other rights are reserved.

Designed By FG	Approved By AE	Created Date 2020-05-26	Units [mm]	General Tolerance SS-ISO 2768-1 m	Scale 1:40	
Material PE, PVC, EN1.4301, MVQ			Project			
Weight [kg] 362.2	Box Volume [m³]		Description Wastop Access DN160 Large			
 www.wapro.com			Stigarrör DN1000 m. betäckning alt. stigarrör med kona			
			Article Number WS160-WA1000-S	Drawing Number ws160-wa1000-en	Rev A	Sheet 1 (1)