

© 2022 Riawatech A/S. This document is subject to copyrights owned by Riawatech A/S. Any amendments, republication, retransmission, and/or reproduction of all or any part of the document is expressly prohibited, unless the copyright owner of the material has expressly granted its prior written consent. All other rights are reserved.

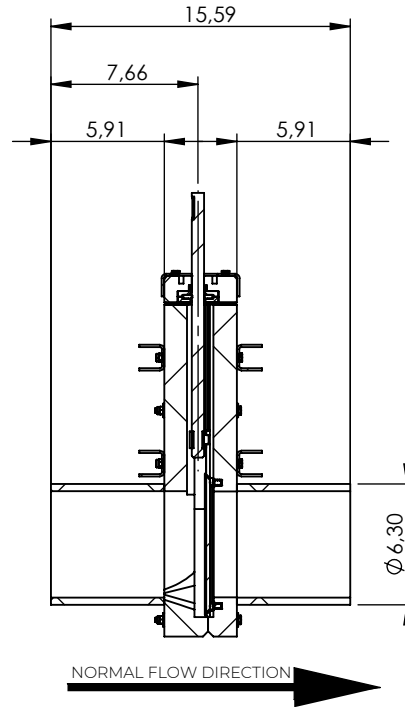
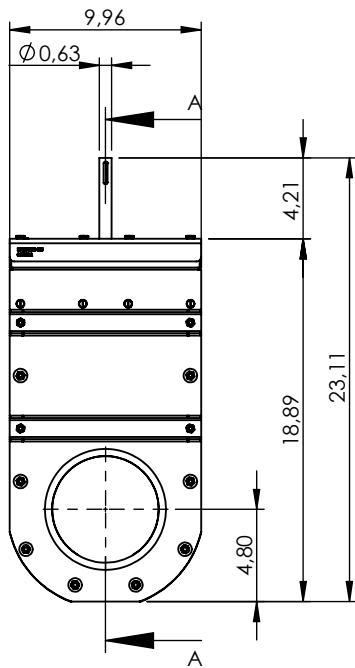
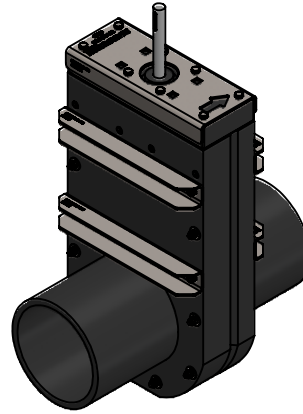
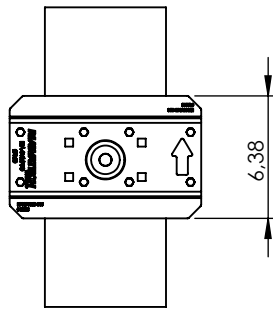

A-A

Approval Signature: \_\_\_\_\_

Date: \_\_\_\_\_

✓	Article No.	Knife gate material	Spindle material	Reinforcement material		
	V70076160	EN1.4404 / AISI 316	EN1.4404 / AISI 316	EN1.4404 / AISI 316		
	V70078160	EN1.4462 / AISI 2205	EN1.4462 / AISI 2205	EN1.4404 / AISI 316		
	V70079160	EN1.4462 / AISI 2205	EN1.4462 / AISI 2205	EN1.4462 / AISI 2205		
Designed By	Approved By	Created Date	Units	General Tolerance	Scale	
PW		2022-08-29	[inch]	ISO 2768-1 m	1:10	
Material			Comment		Updated	
See table					2022-08-29	
Weight [Lbs]		Box Volume [ft <sup>3</sup> ]	Description			
32,08			RIA Stop Valve SVM-TG NPS 6			
 WAPRO GROUP www.riawatech.com			Article Number	Drawing Number	Rev	Sheet
			See table	svm-tg-Ø160-us	A	1 (1)