

© 2022 Riawatech A/S. This document is subject to copyrights owned by Riawatech A/S. Any amendments, republication, retransmission, and/or reproduction of all or any part of the document is expressly prohibited, unless the copyright owner of the material has expressly granted its prior written consent. All other rights are reserved.

NOT FOR PRODUCTION

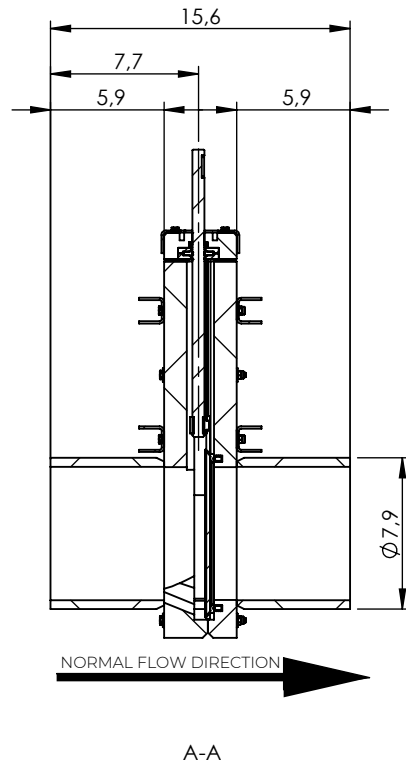
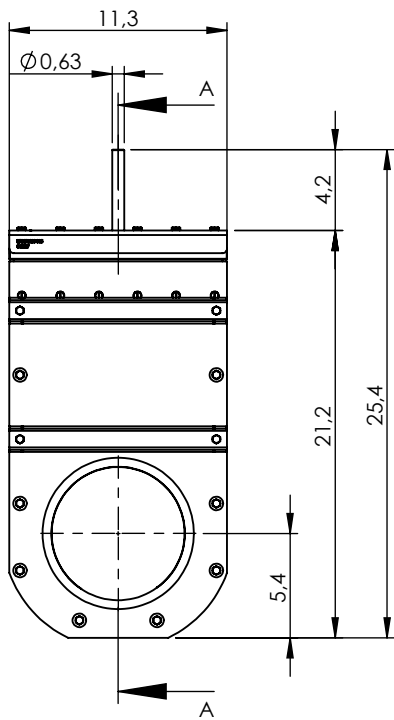
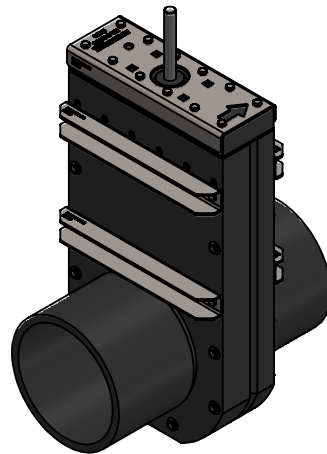
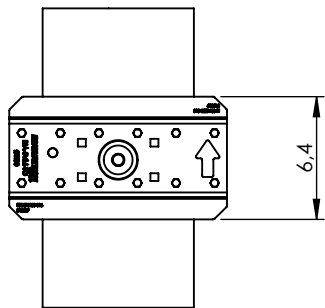

Approval Signature: _____

Date: _____

✓	Article No.	Knife gate material	Spindle material	Reinforcement material
	V70076200	EN1.4404 / AISI 316	EN1.4404 / AISI 316	EN1.4404 / AISI 316
	V70078200	EN1.4462 / AISI 2205	EN1.4462 / AISI 2205	EN1.4404 / AISI 316
	V70079200	EN1.4462 / AISI 2205	EN1.4462 / AISI 2205	EN1.4462 / AISI 2205

Designed By PW	Approved By RI	Created Date 2022-08-29	Units [inch]	General Tolerance ISO 2768-1 m	Scale 1:10	
Material See table		Comment PE100 SDR17			Updated 2022-09-02	
Weight [Lbs] 39.73	Box Volume [ft³]		Description SVM-TG NPS 8"			
 <small>WAPRO GROUP</small> www.riawatech.com			Stop Valve			
			Article Number See table	Drawing Number svm-tg-Ø200_us	Rev A	Sheet 1 (1)