

A-A  
SCALE 1 : 7.5

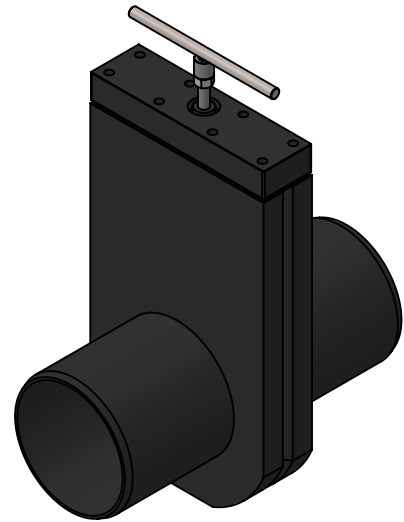
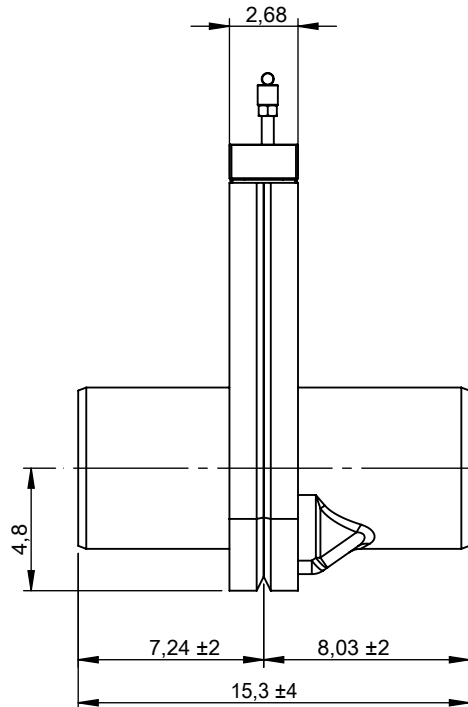

© 2022 Wapro AB. This document is subject to copyrights owned by Wapro AB. Any amendments, republication, retransmission, and/or reproduction of all or any part of the document is expressly prohibited, unless the copyright owner of the material has expressly granted its prior written consent. All other rights are reserved.

Designed By MS	Approved By	Created Date 2022-08-30	Units [inch]	General Tolerance	Scale 1:10		
Material			Comment PE100 SDR26			Updated 16-05-2024	
Weight [Lbs] 16		Box Volume [ft <sup>3</sup> ]	Description WaGate Gate valve SVL NPS/OD 6" AISI 316				
 www.wapro.com			SVL Gate Valve NLS6				
			Article Number	Drawing Number SVL Ø160_US	Rev A	Sheet 1(1)	