

# WARPRO®

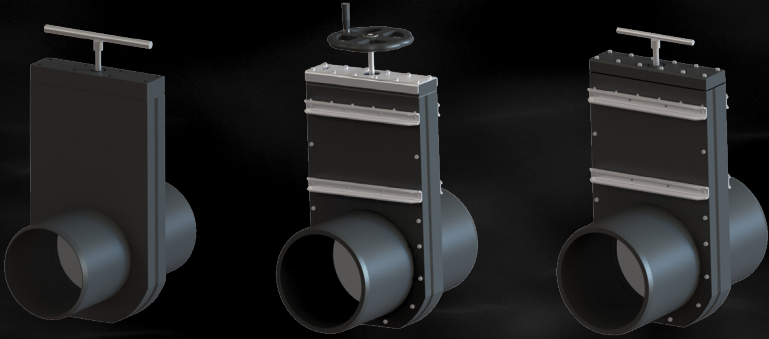

## WAGATE® GATE VALVES

INSTALLATION MAINTENANCE  
& PRODUCT GUARANTEE

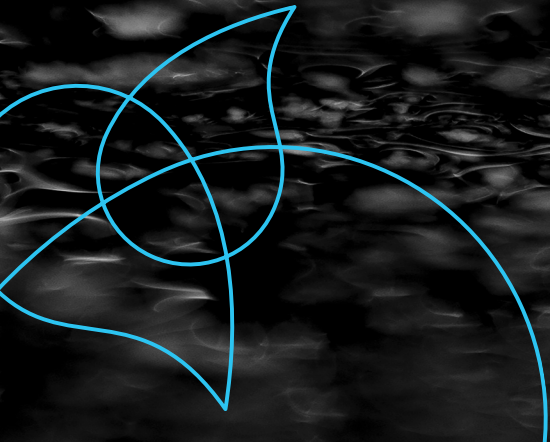

PLEASE NOTE SERIAL/ORDERNUMBER HERE:

**THANK YOU FOR PURCHASING A WAPRO PRODUCT.  
FOR FURTHER PRODUCT INFORMATION PLEASE REFER  
TO WAPRO.COM**

## INDEX

SAFETY INSTRUCTIONS .....	3
TRANSPORT AND STORAGE .....	3-4
MOUNTING .....	5-8
COMMISSIONING .....	9-14
MECHANICAL SETUP.....	9
ELECTRICAL ACTUATOR.....	9
SVL, RVL & SVL-T.....	10
SVM-TG & RVM-TG.....	10
ELECTRIC OPERATION AUMA ACTUATOR, IF SUPPLIED .....	11
SVM-TG - WITH AUMA MULTI-TURN ACTUATOR AND MOTOR CONTROL.....	12-13
ELECTRIC OPERATION LINAK ACTUATOR, IF SUPPLIED .....	14
MAINTENANCE .....	15
MAINTENANCE INSTRUCTIONS .....	16-17
WARRANTY .....	17
EU DECLARATION OF CONFORMITY .....	18

# SAFETY INSTRUCTIONS

WAGATE GATE VALVES – SVL, RVL, SVL-T, SVM-TG & RVM-TG

## SAFETY INSTRUCTIONS

This manual should be read and properly understood before product commissioning. All personnel working with the device must be familiar with the safety and warning instructions in this document.

## STANDARDS/DIRECTIVES

Our products are designed and manufactured in compliance to recognized standards and directives. This is certified in the Declaration of Conformity.

## COMMISSIONING

Before commissioning the user need to check that the product is free of any damages obtained during transport or storage.

Prior to first use, the user needs to make sure that the steps described in the commissioning part of the manual has been followed precisely. If the device is fitted with a third-party actuator, either supplied by the manufacturer or a third party, the user needs to make sure that the setup and commissioning for that product is carried out following that device 's own specific operation instructions.

**Please note** that any actuator supplied by the manufacturer will not have been completely commissioned before shipping, as the setup of electrical connection and communication interface can only be performed on site. We recommend using a trained technician with knowledge of the chosen type of actuator for this task. Commissioning is the sole responsibility of the user. The manufacturer can not be held liable for any consequential damage.

# TRANSPORT AND STORAGE

## TRANSPORT

The device should be kept on its original packaging during the entire transport. The shipment pallet must be kept level and securely fastened down. It is not allowed to stack other products on top of the device during transport.

The device can only be moved on its original shipment pallet or using at least two of the lifting points on the outside of the device (only applicable to valves too large to be handled by hand).

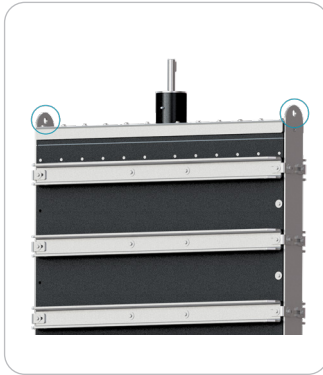
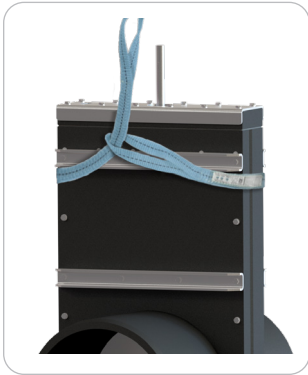

Lifting the product using any other method could result in damage to personnel or the device itself.

## STORAGE

The product must be stored in a dry, well-ventilated environment, away from direct sunlight. Temperatures in storage must be between -30°C and 40°C. The surface temperature of the plastics can't exceed 80°C.

The device must not be flooded or otherwise submerged in water during storage.

If the device is stored outside for longer durations, it is advisable to cover up the inlet pipes to keep dirt and debris out, as well as keeping wildlife from inhabiting the valve.

In areas with high humidity or with big fluctuations in temperature, the transportation wrapping must be removed to avoid buildup of condensation. If the device has an electric actuator it is advised to hook the actuator up to mains power to allow the internal heater to keep condensation from damaging the circuit boards.

## IDENTIFICATION

Do not remove the label. If purchasing spare parts, state the size and type of valve.

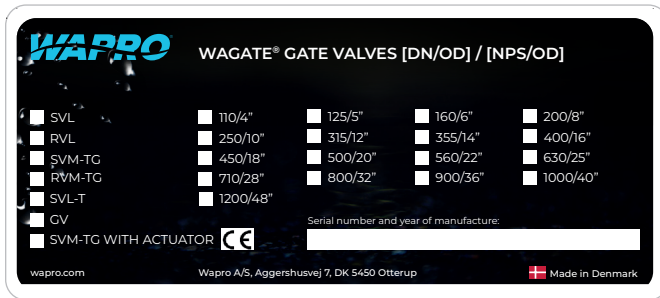

## VALVE APPLICATIONS

The following table shows the applicable uses of each valve type, as well as which types of operation is available. If a valve is used outside its intended application, proper function can't be ensured, contact Wapro for advice.

MODEL	USE			PRESSURE	MANUAL OPERATION		AUTOMATIC OPERATION				
	Waste water	Clean water	Fish farming		One-sided (On-seating)	Two-sided (On/Off-seating)	Push/pull	Spindle	Linak acuator	Auma acuator	Hydraulic cylinder
SVL	✓	*	*	✓		✓		✓		✓	✓
RVL		✓	✓		✓	✓		✓		✓	✓
SVL-T	✓	*	*	✓		✓		✓		✓	✓
SVM-TG	✓	*	*	✓			✓	*	✓	✓	✓
RVM-TG		✓	✓		✓		✓	*	✓	✓	✓

✓ = Recommended solution

\* = Possible solution

[] = Is not recommended

\*As for further information and measurements, we refer to our product specifications

# MOUNTING

This manual should be read and properly understood before mounting. All personnel working with the device must be familiar with the safety and warning instructions in this document.

## MOUNTING DIRECTION

The valve must be mounted so that the arrow on the top of the valve or on the inlet pipe, follows the flow of the media.

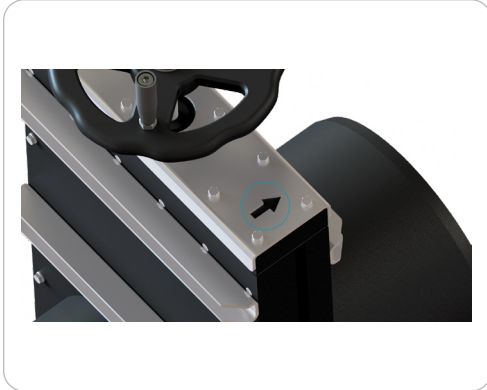

Those valves designed for up- and downstream pressure, RVL and RVM-TG series are bi-directional and have no specified mounting direction.

When mounted the gate valve must not lean more than 45 degrees from vertical in any direction. Violating this can result in reduced watertightness, blockage of moving parts and permanent damage to the valve. If a mounting position exceeding 45 degrees is needed contact Wapro for options.

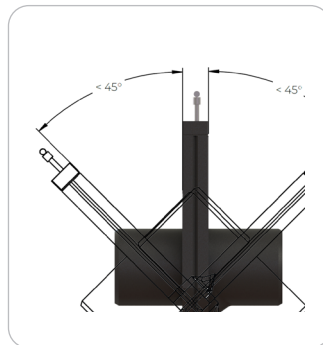
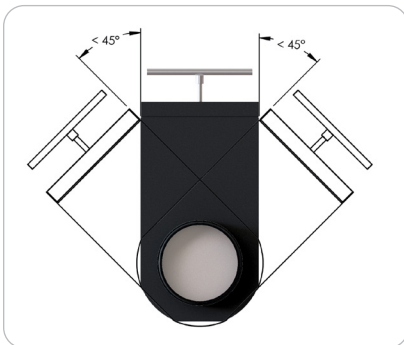

### SERVICE ACCESS

To be able to perform proper repair and servicing of the valve, a volume directly above the head of the valve equal to the height of the valve body must be held free of other piping and components and so that it can be removed.

### SUPPORT

**DN 110-DN 315/NPS 4-NPS 12:** Valves of these sizes are self-supporting and can be hung by their piping without further support. If a valve is fitted with any type of actuator the valve must be supported as described for larger sizes.

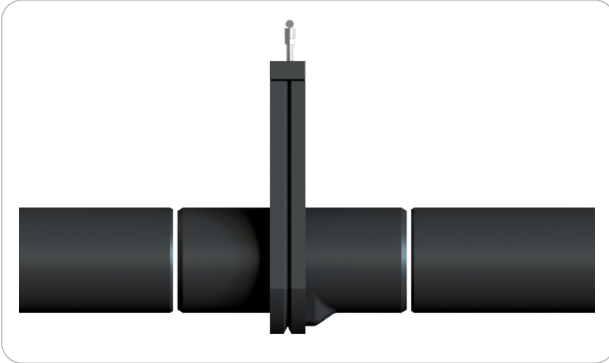

**DN 355/NPS 14 and up:** Valves of these sizes are not self-supporting and must be supported from beneath. The flat contact patch on the bottom of the valve is made to be the main support point for the valve.

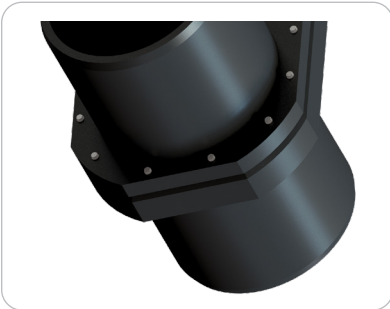

The pipes connected to the device must be completely self-supported even when filled with water, and can't transfer loads into the valve.

The design of the piping system also must take heat expansion into account to make sure that expansion of the connected pipe does not exert forces on the valve.

### **MOUNTING IN GROUND**

All Wapro valves, except for those with actuators, can be mounted directly in soil. The valve should not be mounted deeper than half of the valves pressure rating. Example: for a valve rated for 1bar of water pressure/10 meters of water pressure the max depth in ground is 5 meters.

A large series of extensions of operation are available for all models. See general catalogue for options of contact Wapro. When ordering note that the application is for in ground mounting.

### **MOUNTING ON WALL**

Valves can be manufactured with flanges for mounting directly onto both flat and curved walls.

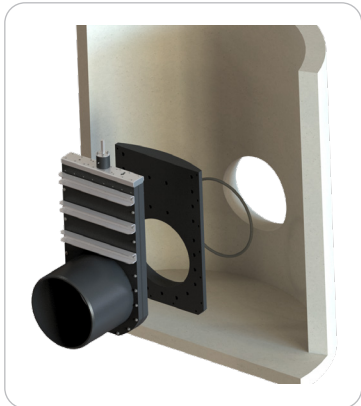

## MOUNTING INTERFACE

The outlet pipes of the valve are made from PEHD100 and can be configured from the factory with either straight pipe spigots, DIN flanges, loose DIN flanges, ANSI flanges or socket joints. For custom mounting solutions contact Wapro.

## OPERATING DEVICES

All Wapro valves are available with a diverse range of operating devices. Both for direct mounting on the valve as well as to extend the operation of the valve. Lengths are made to order. Note that as standard the valves come without any operating device. Handwheel, extensions or other operating devices can always be ordered after initial delivery. Contact Wapro and provide valve type and size.

If a operation extension is used, it is necessary to use wall brackets to eliminate excessive flexing. The brackets should not be placed more than 1,5m apart.



## AMBIENT CONDITIONS

The device is rated for use in temperature between -25°C & 40°C. If the device is used below freezing temperatures the buildup of stagnant water inside the valve is not allowed as ice formation inside the valve can permanently damage it.

## RETROFITTING AN ACTUATOR

If the user wishes to retrofit an actuator, we recommend contacting Wapro for technical information on torque requirements and interface measurements. If an actuator adapter is mounted, the interface on the device follows ISO 5211.



# COMMISSIONING

These steps must be followed closely before first use.

## MECHANICAL SETUP

Before first use retighten all bolts on the valve following the table shown. Tighten the bolts in the head starting in the middle and going around in a circular pattern.

The bolts can have gotten loose under transport and storage due to fluctuations in temperature.

After mounting is completed, slowly move the valve from open to closed. Make sure that there is no sudden resistance to the movement which would indicate a problem.

TORQUE SPEC	M6	M8	M10	M6 IN VALVE HEAD
	7Nm	28Nm	50Nm	12Nm

## ELECTRICAL ACTUATOR

The device can be equipped with different types of electrical actuators, most commonly from the manufacturer AUMA. The connection diagram for the actuator differs between different specifications of the actuator. Therefore, a connection diagram and complete manual is supplied physically with each actuator. If these documents are lost, complete documentation can be downloaded from the following website: <https://www.auma.com/en/service-support/wiring-diagrams>. The order reference for downloading can be found on the nameplate on the side of the actuator.

See pos. 2 on figure 9.1

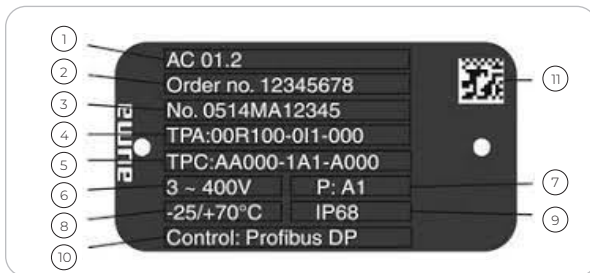

Fig. 9.1

To complete commissioning the complete commissioning step in the operation manual specific to the actuator must be completed.

### SVL, RVL & SVL-T

To close the valve push gently on the valve handle until a natural resistance is met. The valve opening is fully closed slightly before reaching the end of the valves travel. Pressing hard on the handle will not improve valve performance and can lead to permanent damage.

To open the valve, pull on the valve handle. The water pressure pressing on the valve can give a reasonable amount of resistance to initial movement, but this is completely normal behavior. The valve is fully open when a resistance is met.

Never use heavy equipment to move the valve, as excessive force can permanently damage the valve.

If the valve is used in a setting with a lot of vibrations, like near a road, it is recommended to use a position lock to mechanically lock the valve in place. Otherwise, the vibrations can make the valve slowly close over time.

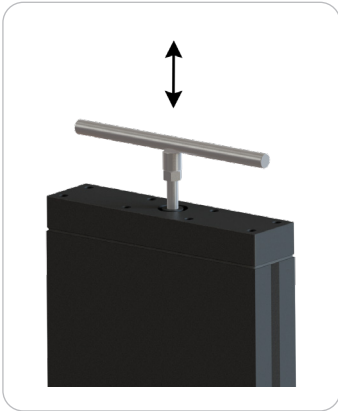

### SVM-TG & RVM-TG

To close the valve, turn the operating device clockwise until a natural resistance is met. The valve opening is fully closed slightly before reaching the end of the valves travel. Applying high torque on the handle will not improve valve performance and can lead to permanent damage.

To open the valve, turn the operating device anti-clockwise until a natural resistance is met. The water pressure pressing on the valve can give a reasonable amount of resistance to initial movement, but this is completely normal behavior. The valve is fully open when a resistance is met.

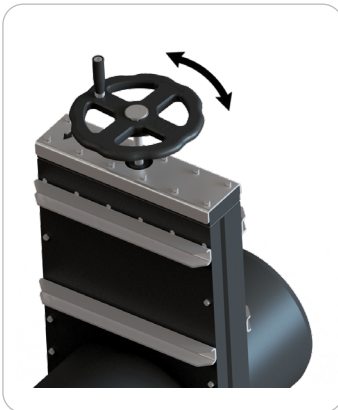

## ELECTRIC OPERATION AUMA ACTUATOR, IF SUPPLIED



### COMMISSIONING

Note that valves supplied with AUMA actuator will not be set up from the factory. To commission the valve either follow the commissioning steps in the AUMA specific manual supplied with the actuator or get the local branch of AUMA to carry out the commissioning. Contact Wapro for further advice.

### LOCAL ELECTRIC OPERATION

To operate the valve using the selector switch [5] is moved into the "Local" position. Then, depending on the current position, either button [1] or [3] is pressed to make the actuator move to the desired position automatically. The actuator will stop when it has reached its programmed end stop. The movement of the valve can be stopped at any time by using button [2]. At all times the current position of the valve can be seen on the display [6] as well as observing the mechanical position indicators.

### REMOTE ELECTRIC OPERATION

To operate the valve remotely the selector switch [5] is moved into the "remote" position. The actuator will no longer react to the local controls and is controlled by the signals sent to it via its connection interface. The precise details of these depend on the configuration of the actuator.

For more information on the connectivity and functionality of the actuator, we refer to the specific operation instructions on the AUMA supplied along with the actuator.

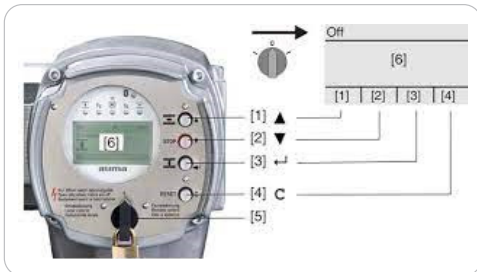

### MANUAL OVERRIDE OPERATION

To activate manual override, press the blue button at the center of the handwheel to engage motion. The handwheel is rotated to move the core. The core rotates in the same direction as the handwheel, meaning that clockwise movement of the handwheel results in clockwise movement of the core. The handwheel is rotated until the mechanical position-indicators pop up showing that is desired position has been reached. Note that the correct alignment of the internal pathway is only reached when the mechanical position indicator is at the peak of its movement. Reactivating the electrical movement automatically disengages the manual override.

## SVM-TG - WITH AUMA MULTI-TURN ACTUATOR AND MOTOR CONTROL

WaGate gate valves can be installed inline on stormwater and wastewater networks. The AUMA electric actuator enables automatic opening and closure of the valve

SVM-TG is as standard, designed to be mounted on a pipeline, i.e., a closed system where there is no natural access to the valve's gate. Therefore, under normal conditions for a standard SVM-TG valve, there is no risk of crush injuries at the valve gate.

Please note: If the assembled SVM-TG is without inlet or outlet pipes, the responsibility for ensuring there is no access to the gate valve during operation lies with the installer of the assembled SVM-TG in a structure or other installation.

**It is assumed that all WaGate valves assembled with an AUMA actuator are operated only by professionally trained operators.**

## INSTALLATION

Please be aware that SVM-TG delivered with AUMA actuators are not pre-configured by Wapro.

To commission the actuator together with the valves, the AUMA-specific manual should be used. Below is a chart that shows the number of rotations for opening/closing and the required torque to set the actuator for a given valve size. See table 12.1.

It is recommended that the installation be carried out by AUMA to ensure proper setting and commissioning of the assembled Shut-off Valves and the actuator.

Dimension	Pressure [bar]	Rotations from closed	Max moment [Nm]
SVM-TG DN/OD 110	6	31	6,0
SVM-TG DN/OD 125	6	34	7,5
SVM-TG DN/OD 160	6	42	12,0
SVM-TG DN/OD 200	6	51	19,0
SVM-TG DN/OD 250	4	63	29,0
SVM-TG DN/OD 315	4	76	46,0
SVM-TG DN/OD 400	2	99	27,0
SVM-TG DN/OD 450	2	113	35,0
SVM-TG DN/OD 500	2	125	43,0
SVM-TG DN/OD 560	2	112	75,0
SVM-TG DN/OD 630	2	123	95,5
SVM-TG DN/OD 700	1	141	60,5
SVM-TG DN/OD 800	1	161	77,0
SVM-TG DN/OD 900	1	177	97,0
SVM-TG DN/OD 1000	0,5	163	70,0
SVM-TG DN/OD 1200	0,5	195	100,0

Table 12.1

## COMMISSIONING

The valve can be operated locally or remotely controlled. For further information, please see s. 11.

If the assembled valve is without outlet or inlet pipes, the responsibility for ensuring that there is no access to the SVM-TG damper plate during operation lies with the installer.

## MAINTENANCE

When servicing and maintaining the assembled SVM-TG, it is crucial to ensure that the rotary switch (5) on the AUMA control panel is set to position 0 and that it is locked. When the rotary switch is in position 0, the valve can be operated manually using the handwheel on the AUMA actuator. Please see s. 11.

Maintenance of the AUMA actuator should be carried out in accordance with AUMA's manual. It is recommended that service and maintenance be performed by AUMA.



### **Risk of crush injuries due to incorrect use!**

Ignoring the warning can lead to serious injury, or in the worst case, death.

- When performing maintenance on the WaGate gate valve (or any activity where personnel come in contact with the valve), the power supply to the AUMA multi-turn actuator must be disconnected by ensuring that the selector switch is in position 0 [5] and locked in this position.

- Only trained and authorized personnel may operate the multi-turn actuator and perform maintenance on the WaGate gate valve.

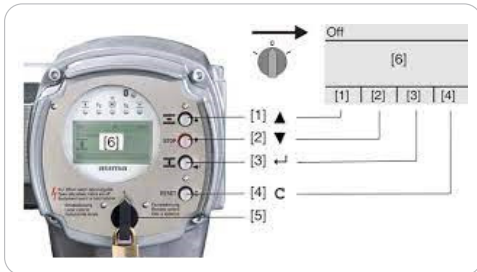

## ELECTRIC OPERATION LINAK ACTUATOR, IF SUPPLIED

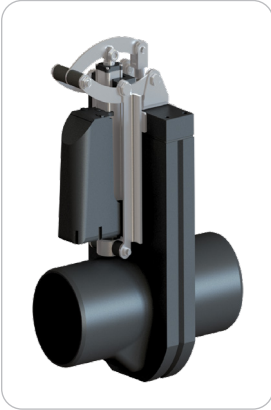

### COMMISSIONING

The valve with actuator and controller is delivered ready to use with the basic setup already carried out. For more advised options, including remote control some setup is required. See the specific controller documentation for setup procedures. The documentation can be found here: <https://www.linakthirdparty.com/products/motor-controllers-and-drivers/wcu/#/brochuresmanualsandbussetupfiles>

### LOCAL ELECTRIC OPERATION

To use the valve, the controller has to be in the "local operations" mode, activated by pressing the button [2] shown on the figure below. Note that when in this mode remote controls are inactive and will only be activated by pressing the [2] again.

To open the valve press and hold the "Up" button [1]. To close the valve, press and hold the "Down" button [3].

The current position of the valve is shown on the display [4], 0% indicates a fully closed valve and 100% indicates fully open. The valve will automatically stop when it reaches its programmed end stop.



### REMOTE ELECTRIC OPERATION

To operate the valve remotely the button [2] has to be pressed to get the controller into "remote" position.

The actuator will no longer react to the local controls and is controlled by the signals sent to it via its connection interface. The precise details of these depend on the configuration of the controller.

# MAINTENANCE

The following maintenance must be performed for the product to operate as intended. Failing to do so voids the warranty.

## MAINTENANCE PLAN

It is recommended that maintenance be conducted every six months. However, it is advisable to develop a maintenance schedule that is specifically tailored to the application and environmental conditions in which the valve operates.

- To check for proper function, a full open/close operation must be performed. Long periods without use can cause the gaskets to get stuck in place. The valve should operate smoothly and without sudden resistance. Jerking motion is a sign of sticking gaskets.
- Refill the bearing housing with bearing grease using the grease nipple. SKF LGWA 2/0.4 or similar is recommended for 0-40°C. For temperatures below freezing a lower viscosity grease is recommended. (Only applies to SVM-TG and RVM-TG sizes DN710/NPS28 and above)



- Inspect the device for visual signs of damage. If any significant damage is found, please contact Wapro for advice.

## EVERY 12 MONTHS

- If supplied with AUMA actuator, the actuator has an internal movement counter to keep track of movements. The gaskets should be inspected for wear or tears. This can either be done using a camera sent through the pipe system or by disassembling the valve (Described on the following pages)

# MAINTENANCE INSTRUCTIONS

Disassembly of valve to change internal components or gaskets.  
Note that this service must be done while the valve is not under pressure.

1. To make the service easier, the valve should be fully open before starting.
2. Remove the handwheel or any other operating device present.
3. Loosen the screws in the head of the valve.
4. Carefully remove the head from the valve. Be careful not to damage the seals in the head when removing the head.
5. Unscrew the spindle from the spindle nut (only applicable to SVM-TG & RVM-TG)
6. If the gasket must be changed a thin piece of plastic has to be inserted into valve between the gate and the gasket, before removing the gate. Otherwise reinserting the gate is impossible without damaging the gate. Gasket change is only possible on sizes DN400/NPS16 and up, and not on valves with double seals (RVM-TG).

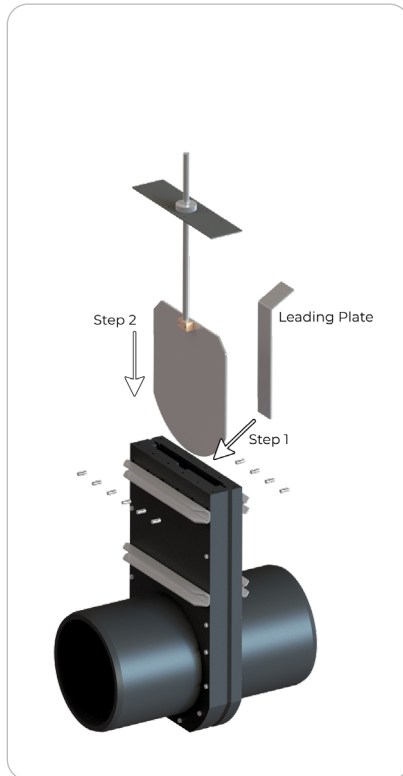
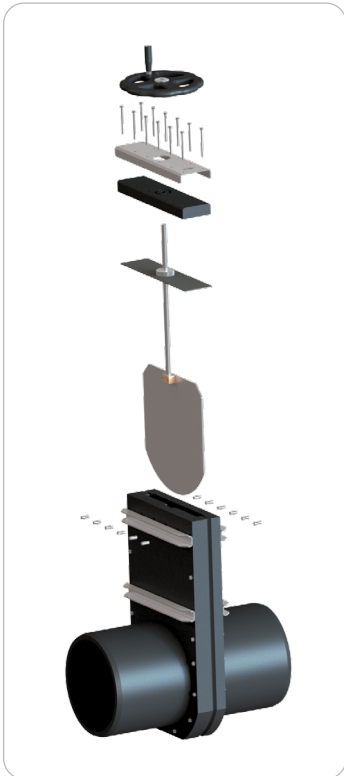

SVM-TG and RVM-TG



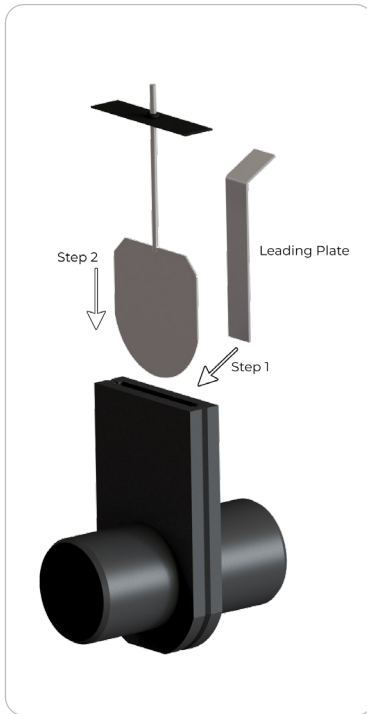
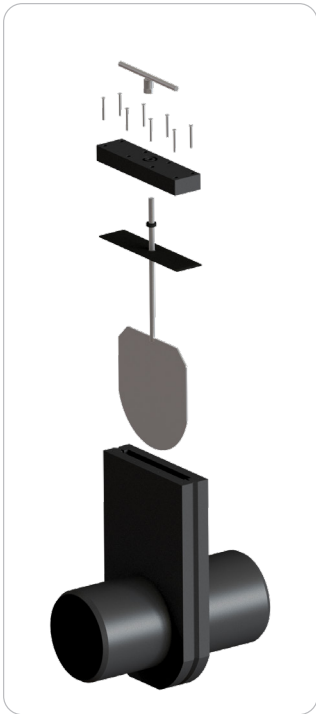

SVL and RVL

## WARRANTY

### WAPRO A/S WARRANTY

Wapro will remedy defects in material and/or workmanship in any new Wapro valve for a period of two (2) years from the documented date of purchase so long as the valve has been used in accordance with Wapro's instructions and recommendations and under normal operating conditions. The warranty does not cover damage to the valve caused by external mechanical forces, such as interference from humans, animals or machines, nor is the warranty valid if the valve has been modified or altered in any way post-production. Furthermore, the warranty is not valid (a) if the valve is damaged due to exposure to high concentrations of chemical substances, (b) if the valve is damaged because of pressure spikes, water hammering or vacuums exceeding the rated limits, (c) the warranty is invalid if flow velocity exceeds what is recommended, and (d) if malfunctions are caused by other equipment.

To request warranty service, the buyer should contact the WaGate dealer where the valve was purchased within a reasonable time after discovering any defects. The valve serial number or order number must be quoted in the case of a warranty claim. Wapro's liability is limited to the replacement or repair of the defective valve. Wapro will not assume costs incurred for removal of defective valves or subsequent installation of replacement valves. Furthermore, Wapro will not assume transportation costs of damaged valves or replacement valves. Wapro warrants that repaired or replaced valves are covered for the greater of either the remainder of the original valve warranty or 90 days. THE WARRANTY EXPRESSED ABOVE SHALL BE IN LIEU OF ANY OTHER WARRANTIES, EXPRESSED OR IMPLIED, INCLUDING, WITHOUT LIMITATION, ANY IMPLIED WARRANTIES OR CONDITIONS OF MERCHANTABILITY, FITNESS FOR A PARTICULAR PURPOSE AND NONINFRINGEMENT WHICH ARE EXPRESSLY DISCLAIMED, AND IS IN LIEU OF ANY AND ALL OTHER OBLIGATIONS OR LIABILITY ON WAPRO PART. TO THE MAXIMUM EXTENT PERMITTED BY APPLICABLE LAW, UNDER NO CIRCUMSTANCES WILL WAPRO BE LIABLE TO BUYER FOR ANY INDIRECT, INCIDENTAL, SPECIAL OR CONSEQUENTIAL DAMAGES (INCLUDING ANY DAMAGE FOR LOSS OF REVENUE OR PROFIT), OR OTHERWISE ARISING OUT OF OR IN CONNECTION WITH FURNISHING OF THE VALVES, PARTS OR SERVICE HEREUNDER, OR THE PERFORMANCE, USE OF, OR INABILITY TO USE, ANY OF THE VALVES, PARTS OR SERVICE, OR OTHERWISE, WHETHER BASED IN CONTRACT, WARRANTY, TORT, INCLUDING WITHOUT LIMITATION, NEGLIGENCE OR ANY OTHER LEGAL OR EQUITABLE THEORY. TO THE MAXIMUM EXTENT PERMITTED BY APPLICABLE LAW, THE REMEDIES SET FORTH IN THIS LIMITED WARRANTY SHALL APPLY EVEN IF SUCH REMEDIES FAIL THEIR ESSENTIAL PURPOSE. FOR THE AVOIDANCE OF DOUBT, NO EMPLOYEE, AGENT OR OTHER REPRESENTATIVE OF WAPRO IS AUTHORIZED TO EXTEND OR OTHERWISE MODIFY THE WARRANTY SPECIFIED HEREIN.

# EU DECLARATION OF CONFORMITY

for gate valves aimed to shut off and/or control flows on stormwater and wastewater networks, integrated with an electric multi-turn actuator to automate the opening and closing of the valve.

**Manufacturer Gate valve:**

Wapro A/S, Aggershusvej 7, DK-5450 Otterup, Denmark

**Denomination/model:**

WaGate® Gate Valve SVM-TG

**Manufacturer actuator:**

AUMA Scandinavia AB

Wapro hereby declares that this machinery, the WaGate® Gate valve SVM-TG integrated with an AUMA electric multi-turn actuator, fulfils all the applicable requirements of the Machinery Directive 2006/42/EG. The risk analysis has been carried out using DS/EN ISO 12100:2011 *Safety of machinery – General principles for design – Risk assessment and risk reduction*.

---

This machinery also complies with the leakage rates according to table 1, class 5, in the standard:

DIN 19569-4:2000-11

*Wastewater treatment plants - Principles for the design of structures and technical equipment - Part 4: Specific principles for shutoff devices as penstocks, sluice gates, stoplogs etc.*

---

Furthermore, Wapro declares that the Gate valve is manufactured and delivered in line with:

FPC (Factory Product Control)

FPC is made according to Wapro A/S FPC-movement and presser test for Wagate Gate Valves SVM-TG (rev. 1)

---

The person responsible to compile the technical file: Morten Skjold, Aggershusvej 7, DK-5450 Otterup, Denmark

This declaration relates exclusively to the machinery in the state in which it was placed on the market, and excludes constructions applied and/or functional changes added subsequently by the final user. The declaration is only valid if the installation of the WaGate Gate valve SVM-TG integrated with AUMA electrical actuator is made according to the installation, operation and maintenance manual provided by Wapro A/S.

This declaration was, on behalf of Wapro Group, drawn up by:



---

Morten Skjold                      Date: 22/5-2024  
Factory Manager  
COO                                      Place: Otterup

**CONTACT WAPRO**

customerservice@wapro.com  
wapro.com

SE: +46 (0)454 185 10  
DK: +45 64 82 40 00  
US: +1 888 927 8677  
UK: +44 114 308 0123

Wapro A/S, Aggershusvej 7, DK 5450 Otterup

Rev 2.0

