

GATE VALVE - SVM-TG DN/OD 710-1200

AREA OF USE: Sewer and stormwater, process water and for the fishing and agricultural industry. SVM-TG is for one-sided pressure.

ADVANTAGES WITH WAGATE SVM-TG:

- Can be connected to the pipeline network with coupling, electric coupling, flanges, or welded together in open terrain
- Is designed with full flow and with a self-cleaning pocket, which ensures total closure of the valve blade
- Long lifespan. Low operating and maintenance cost
- The O-ring seal against the valve blade can be replaced in larger valves
- Can be built into the pipeline inside and outside well systems with spindle extensions and protective tubes in PEH
- The valve is suitable for installation in the ground without any form of protection



OPERATION: SVM-TG has a non-rising spindle and is operated with a handwheel or with an adapter and extension rod.

Can be used with electric, pneumatic, or hydraulic actuators.

SPECIAL DESIGN: For aggressive media, the spindle/nut is mounted outside the valve body.

MATERIAL:

Valve body	PEHD 500
Reinforcement profiles	EN 1.4404, (EN 1.4462)
Valve blade	EN 1.4404, (EN 1.4462)
Spindle	EN 1.4571 (EN 1.4462)
Spindle nut	Tin bronze (Cu2Sn12)
Valve gasket	EPDM (NBR)
Top gasket	EPDM
Bearing	PEHD 300
Tätningarring	NBR

TECHNICAL DATA:

Maximum pressure	DN/OD 710-1200
	contact us
Temperature	-50° C - +80° C

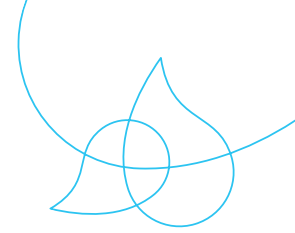

GATE VALVE - SVM-TG DN/OD 710-1200

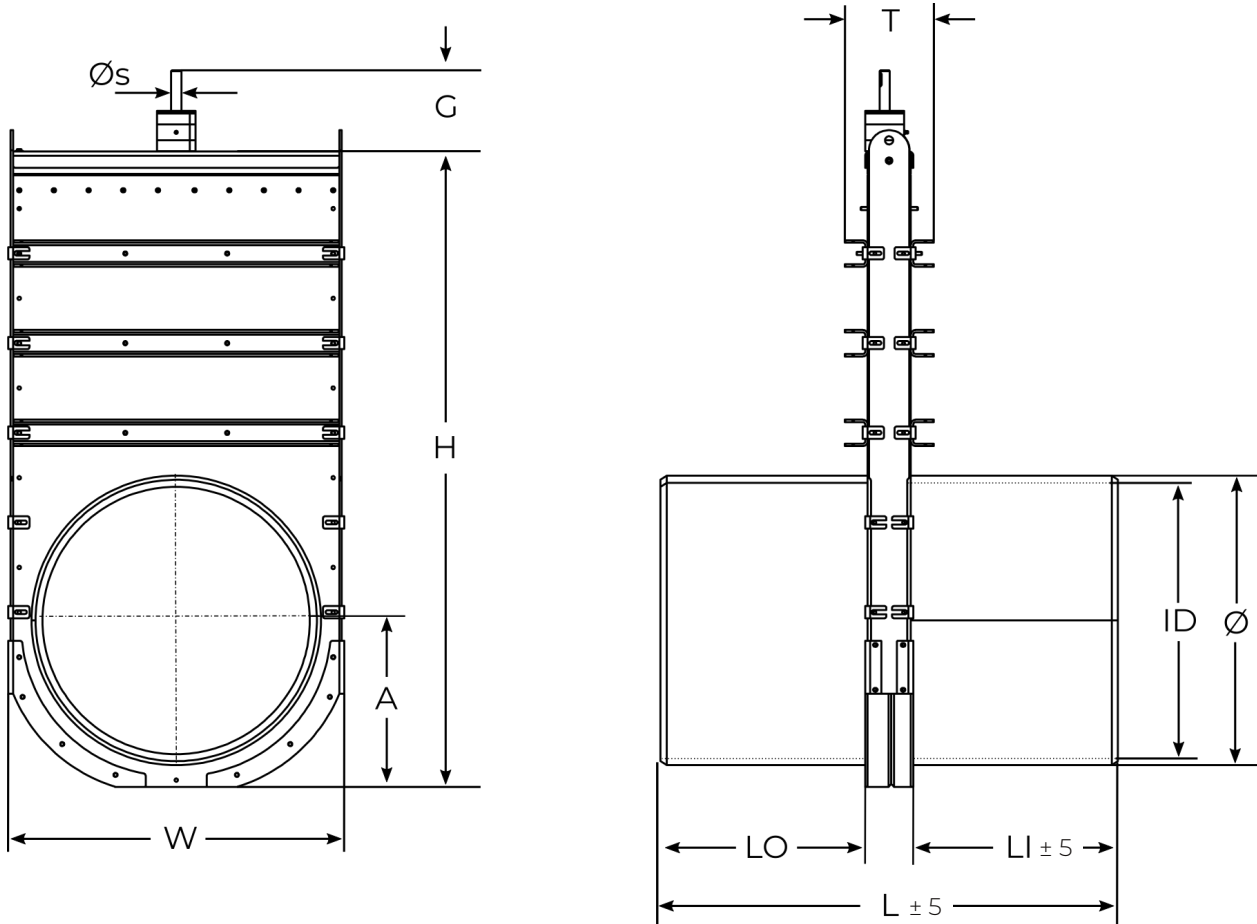

DIMENSIONS IN [MM]

DN/OD	Ø	ID	W	H	A	G	ØS	L	LO	LI	T	WEIGHT [KG]	NM	BAR	PIPE
700	700	655.6	812	1558	408	200	25	1122	556	566	210	203	60,5	1	SDR26
800	800	738.8	912	1768	480	200	25	1246	618	628	210	264	77,0	1	SDR26
900	900	831.2	1012	1948	520	200	25	1368	678	690	210	341	97,0	1	SDR26
1000	1000	923.6	1112	2173	600	200	30	1510	748	762	230	570	70,0	0,5	SDR26
1200	1200	1108.2	1312	2549	700	200	30	1708	848	860	250	689	100,0	0,5	SDR26

Other dimensions on request. Reserves the right to changes.