

WASTOP® FLOORDRAIN



incl. WaStop Inline check valve and flexible coupling

AREA OF USE:

The WaStop Floor drain is designed to ensure that property owners never have to worry about basement flooding or damage to their belongings during heavy rainfall or melting periods.

During intense rain, water can be directed from the drainage system and up through the drain. This water can then enter through the basement door, causing significant damage. To prevent damage to the property, basement, furniture, and electronic equipment, an effective solution is required.

That is why the WaStop Floor drain is integrated with the WaStop Inline check valve.

When back pressure occurs from the drainage system and water flows back towards the floor drain, the WaStop Inline check valve prevents water from rising out of the well and further into the property through the door.

This ensures that the property remains dry and protected from flooding.

The WaStop Floor drain is an innovative climate-proofing solution to prevent flooding.

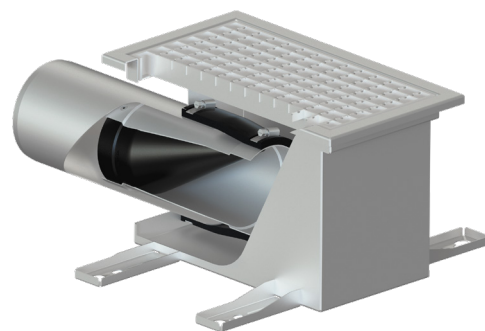

THE BENEFITS OF WASTOP® FLOOR DRAIN:

- Reliable and efficient solution for rain- and snowmelt and also flood prevention
 - Integrated WaStop Inline check valve prevents water intrusion into the property
 - Easy installation and maintenance
 - Sustainable and robust construction ensuring a long lifespan
 - Designed for installation in concrete floors, and installation is facilitated with the help of adjustable legs
 - Load class L15: Suitable for areas with light vehicle traffic, excluding truck traffic
- Tested according to SS-EN 1253-1 with a load of 10 kN. Maximum point load is one-third of the maximum load weight

DIMENSIONS:

LENGTH	WIDTH	HEIGHT	SIZE GRATE	DIAMETER	TOTAL WEIGHT INCL. STABILIZER LEG	TOTAL WEIGHT EXCL. STABILIZER LEG	MAX VOLYME FLOW	OPENING PRESSURE S2 FROM PIPE INVERT	CLOSING PRESSURE S2 FROM PIPE INVERT
[mm]	[mm]	[mm]	[mm]	[mm]	[KG]	[KG]	[L/S]	[mm]	[mm]
522	388	208	150x305	110	6,8	6,1	3,4	130	55

Contact: wapro.com +46 (0)454 185 10 sales@wapro.com
Contact GB and IE: wapro.com +44 114 308 0123 sales@wapro.com





INSTALLATION:

The product is specifically designed to operate with minimal opening force when the water level in the drain is low and can be installed in confined spaces.

With the help of the accompanying adjustable legs, installation becomes easy. The legs are adjusted from above using bits and a screwdriver. The total adjustable height for the WaStop Floor drain is 300 mm.

HOW AND WHERE CAN THE WASTOP FLOOR DRAIN BE INSTALLED:

- It can be placed or mounted at the bottom of the basement stairs or at the bottom of the garage driveway
- At the lowest point outside the basement door or garage door
- Integrated into the concrete structure of basement stairs or basement entrances
- In other locations where there is a risk of water or sewage leakage from external sources

