

NORMAL FLOW DIRECTION

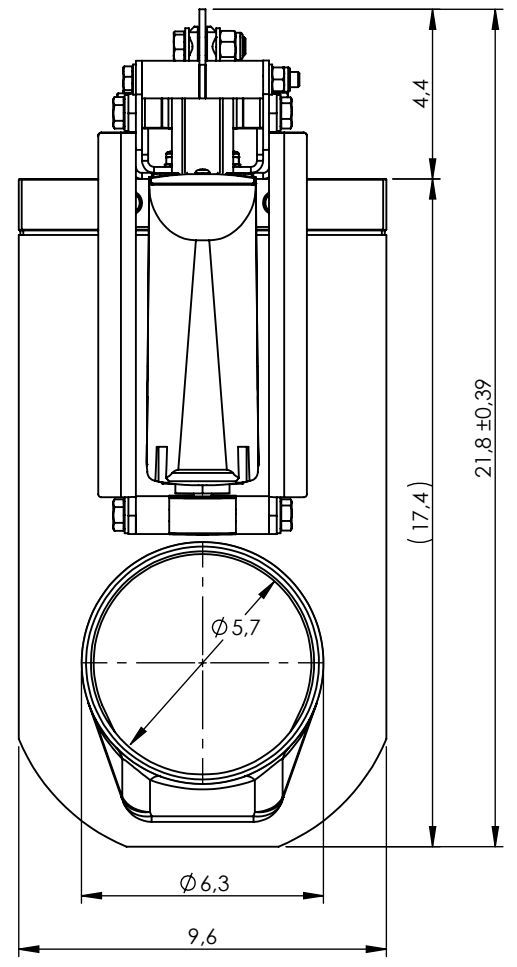
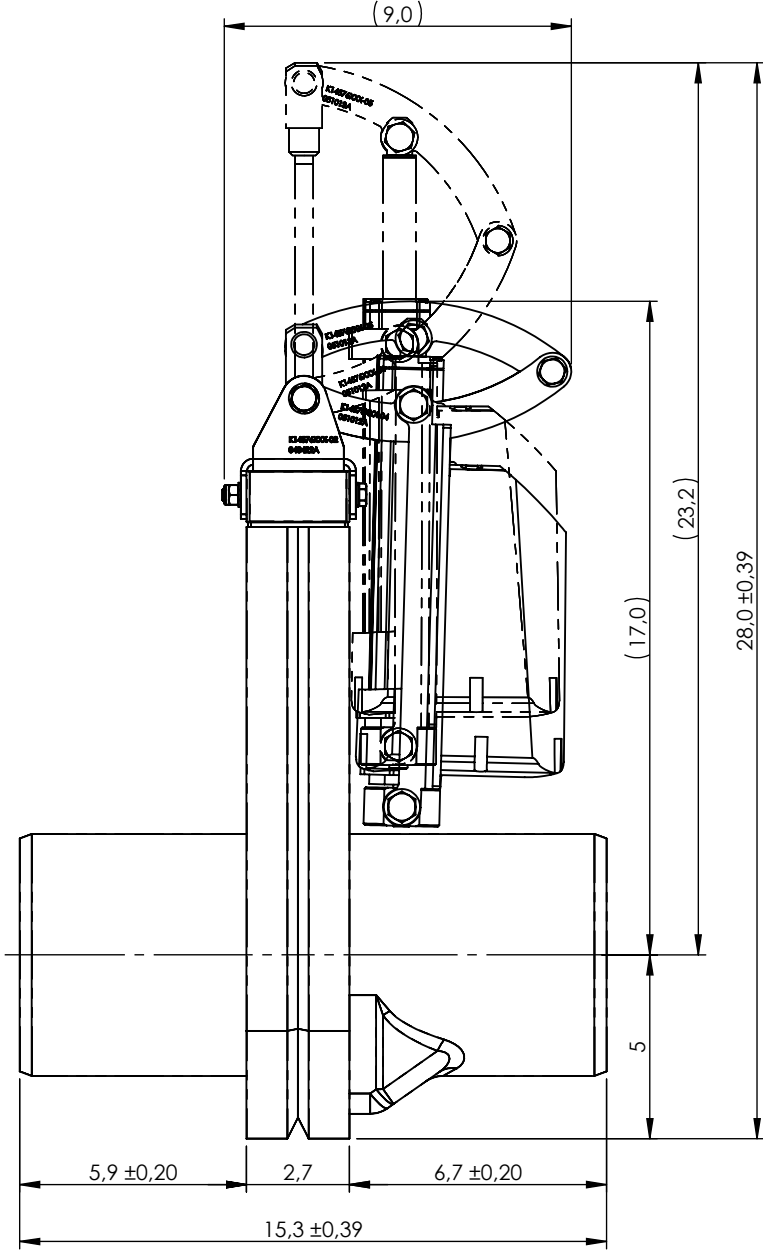
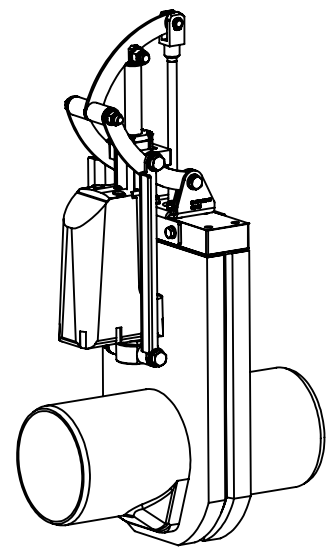

© 2022 Wapro AB. This document is subject to copyrights owned by Wapro AB. Any amendments, republication, retransmission, and/or reproduction of all or any part of the document is expressly prohibited, unless the copyright owner of the material has expressly granted its prior written consent. All other rights are reserved.

Designed By RI	Approved By	Created Date 2024-12-06	Units [inch]	General Tolerance	Scale 1:10		
Material PEHD 100, PEHD 500, Aisi 316 and other			Comment			Updated 02-01-2025	
Weight [Lbs] 30		Box Volume [ft³]	Description WaGate Gate valve SVL NPS/OD 6 AISI 316 Scissors LA33				
 www.wapro.com			WaGate Gate Valve SVL DN/OD 160 AISI 316 scissors LA33				
			Article Number V14576160	Drawing Number SVL Ø6_Linak_Scissors-US	Rev A	Sheet 1 (1)	