

← NORMAL FLOW DIRECTION

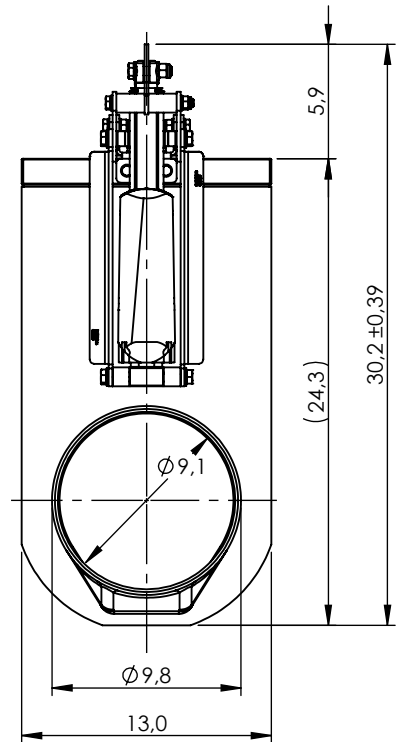
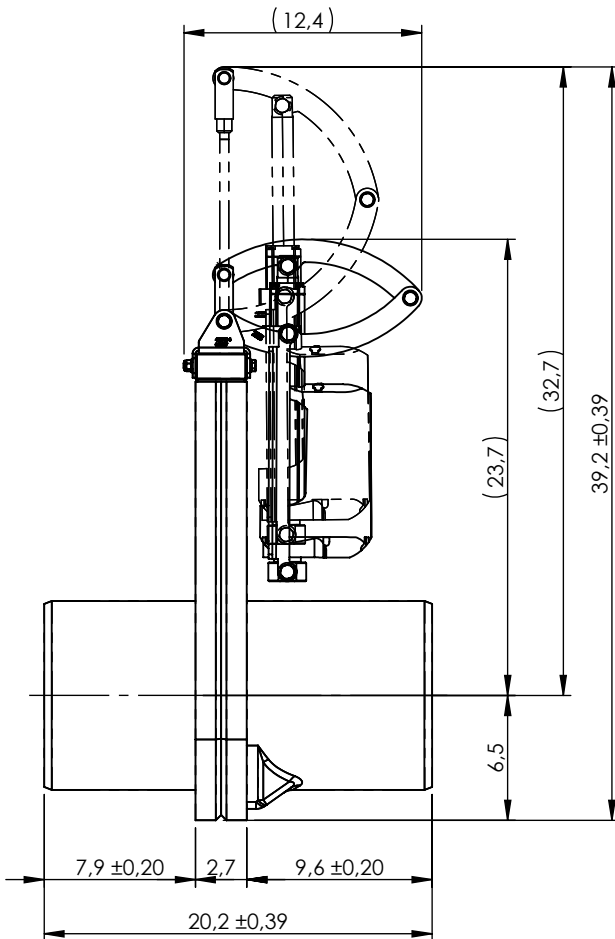
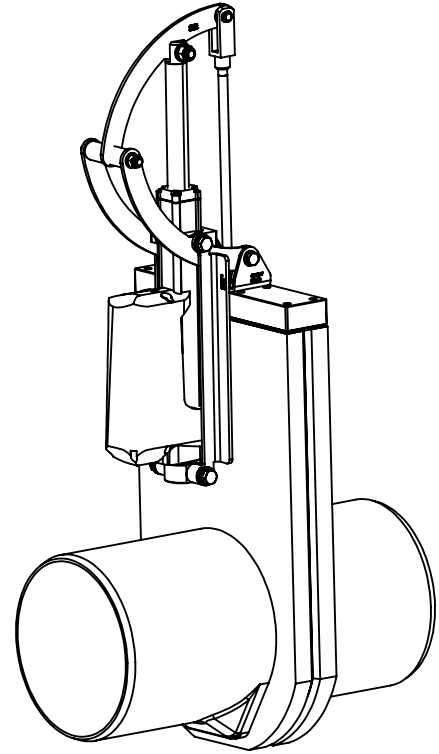

© 2022 Wapro AB. This document is subject to copyrights owned by Wapro AB. Any amendments, republication, retransmission, and/or reproduction of all or any part of the document is expressly prohibited, unless the copyright owner of the material has expressly granted its prior written consent. All other rights are reserved.

Designed By RI	Approved By BL	Created Date 2024-12-10	Units [inch]	General Tolerance	Scale 1:10	
Material Aisi 316/EN 1.4404, PEHD, EPDM and other		Comment			Updated 02-01-2025	
Weight [Lbs] 48		Box Volume [ft³]		Description WaGate Gate valve SVL NPS/OD 10 AISI 316 Scissors WaGate Gate Valve SVL DN/OD 250 AISI 316 scissors LA36		
 www.wapro.com			Article Number V14576250	Drawing Number SVL Ø10_Linak_Scissors-US	Rev A	Sheet 1 (1)