

SLUICE GATE - SPS-TG NPS 8-24

AREA OF USE: Sewer and stormwater, industrial facilities and process water.

SPS-TG seals from the mounting side.

ADVANTAGES WITH WAGATE SPS-TG:

- No welding of frame or damper plate, which reduces the risk of corrosion, therefore longer operational life
- Encapsulated bearing and sliding parts built into PEHD housing, thereby no degradation from the medium
- No rising spindle, thereby requiring less space
- Square or circular opening with the possibility of tight pipe connection to damper. Can be manufactured with a rounded flange for installation in a chamber
- O-ring seal mounted in PEHD for replacement when worn. All bearings and sliding parts are encased in PEHD round part for pressure lubrication.



OPERATION: Manually with hand wheel. Can be used with electric, pneumatic, or hydraulic actuators.

SPECIAL DESIGN: Spindle and nut above surface level (pedestal-mounted)

MATERIAL:

Frame	EN 1.4404 & PEHD
Damper plate	EN 1.4404
Spindle	EN 1.4571 (EN 1.4462)
Spindle nut	Tin bronze (Cu2Sn12)
Seal against the damper plate	EPDM
Seal against the wall	EPEM sponge rubber

TECHNICAL DATA:

Sealing according to	DIN 19569-4 Table 1
----------------------	---------------------

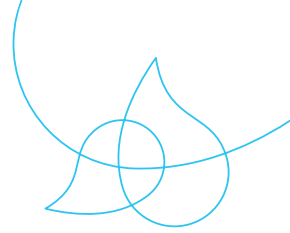

SLUICE GATE - SPS-TG NPS 8-24

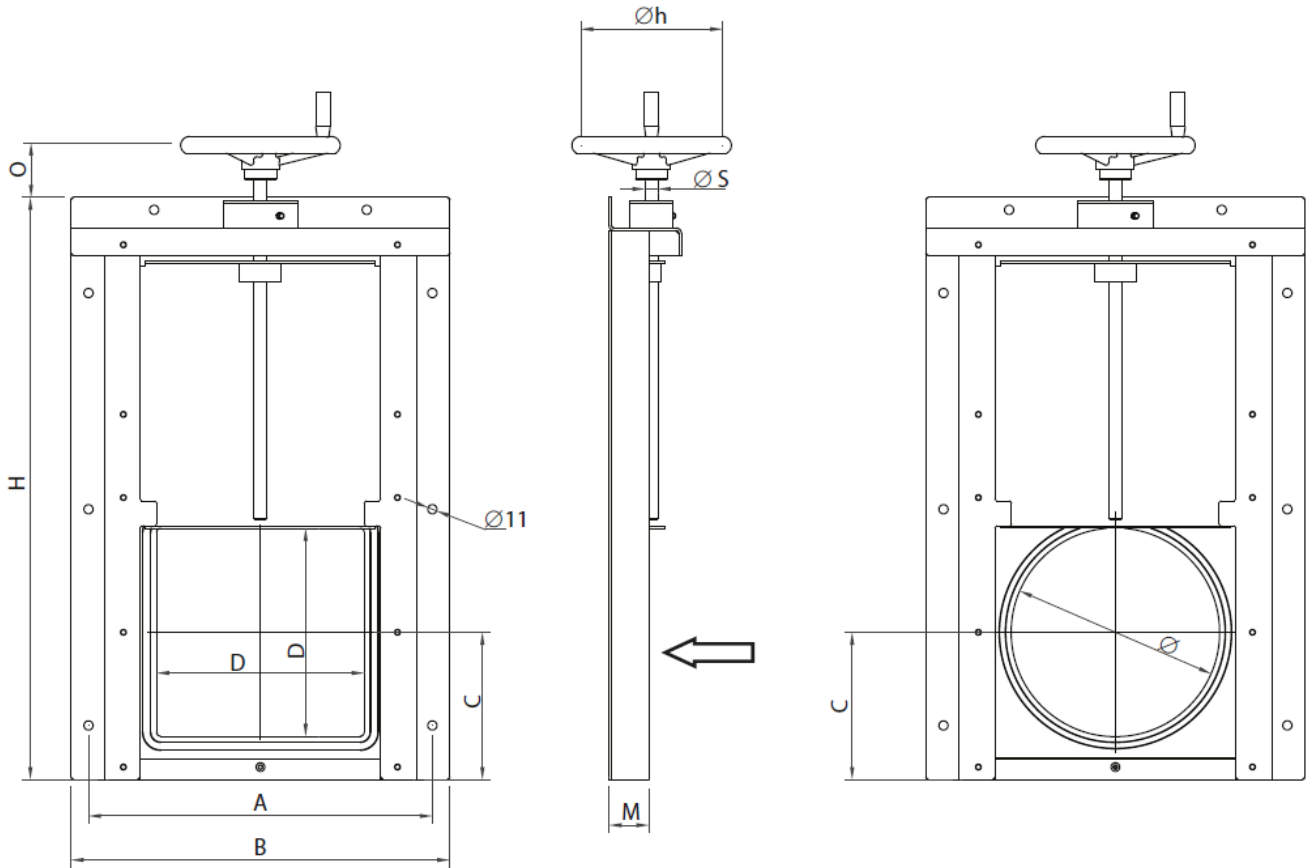

DIMENSIONS IN [INCHES]

NPS	D	Ø	A	B	C	H	M	O	ØS	ØH	WEIGHT [LBS]	MWC
8	8x8	7,87	14,33	15,98	5,98	23,62	1,9	2,56	0,71	7,87	28,7	4
10	10x10	9,84	16,30	17,95	6,97	27,56	1,9	3,15	0,71	9,84	35,3	4
12	12x12	12,40	18,86	20,51	8,27	31,69	1,9	2,36	0,71	9,84	41,9	4
16	16x16	15,75	22,20	23,86	9,92	39,37	1,9	3,15	0,71	12,40	55,1	4
20	20x20	19,69	26,14	27,80	11,89	47,24	1,9	3,15	0,87	12,40	72,8	3
24	24x24	24,80	31,26	32,91	14,37	56,81	1,9	3,94	0,87	12,40	88,2	3

Other dimensions on request. Reserves the right to changes.