

© 2022 Wapro AB. This document is subject to copyrights owned by Wapro AB. Any amendments, republication, retransmission, and/or reproduction of all or any part of the document is expressly prohibited, unless the copyright owner of the material has expressly granted its prior written consent. All other rights are reserved.

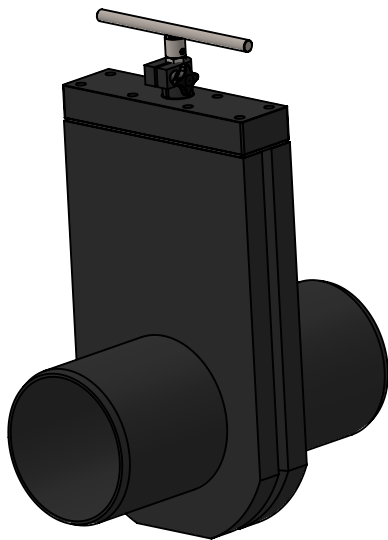
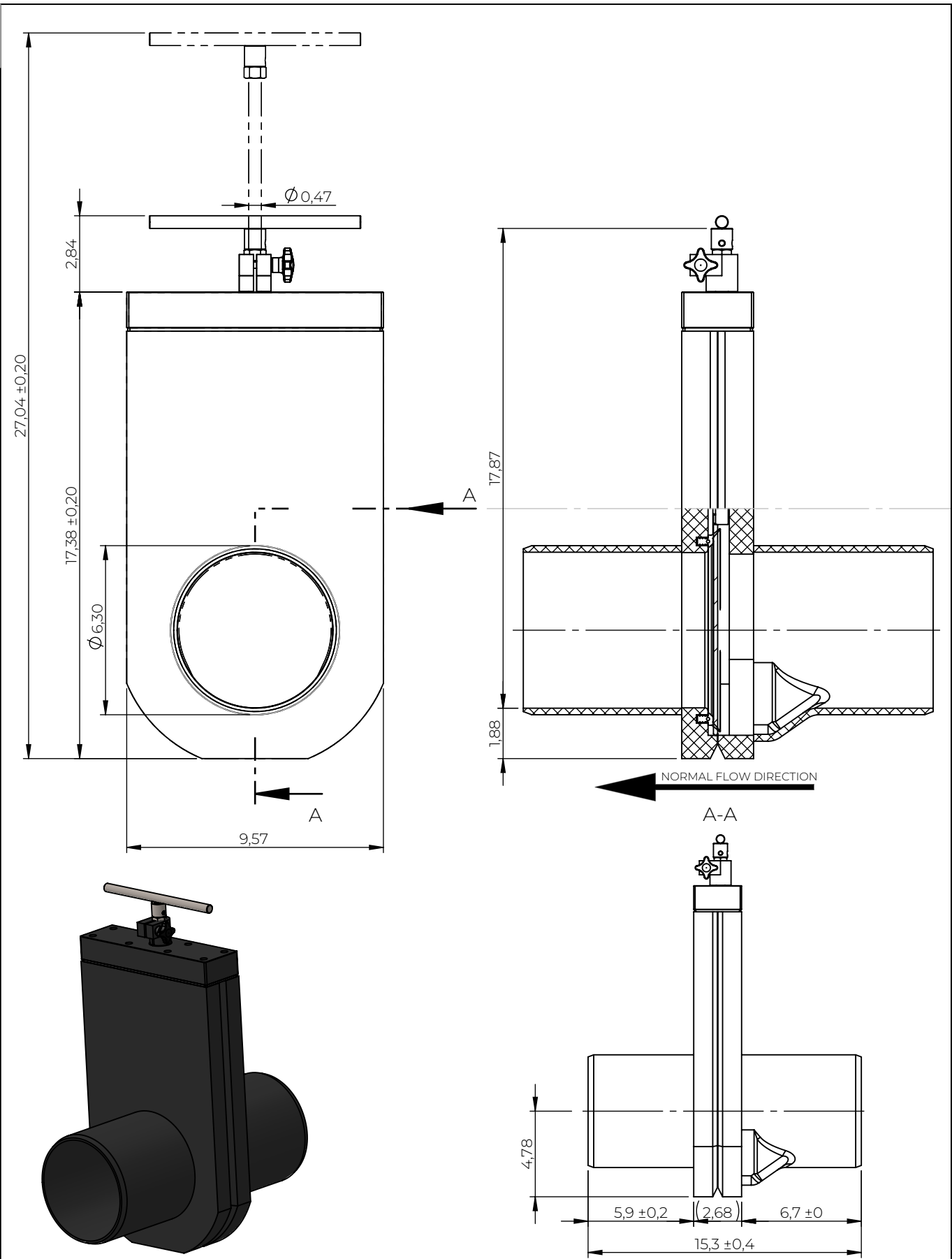

Designed By RI	Approved By	Created Date 2024-10-15	Units [inch]	General Tolerance	Scale 1:5		
Material			Comment			Updated 26-02-2025	
Weight [Lbs] 16	Box Volume [ft <sup>3</sup> ]		Description WaGate Gate valve SVL NPS/OD 6" AISI 316 WaGate Gate Valve SVL DN/OD 160 AISI 316				
 www.wapro.com			Article Number V13076160	Drawing Number SVL Ø6_US	Rev	Sheet 1 (1)	