

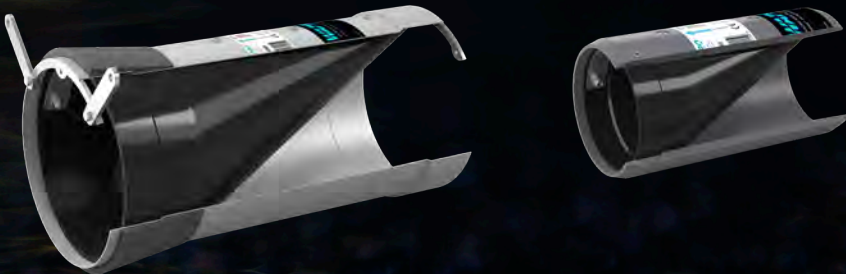

EN

WASTOP INLINE CHECK VALVE

INSTALLATION MAINTENANCE & PRODUCT GUARANTEE



- ☒ PVC DN100-200 Standard (NPS 4"-8")
PVC DN75-200 Soft/Hard (NPS 3"-8")
PE DN200-315 Standard/Soft/Hard (NPS 8"-12")
- ☒ Stainless Steel DN100-200 Standard (NPS 4"-8")
Stainless Steel DN100-1800 Soft/Standard/Hard (NPS 4"-72")

Please note your product serial number:

**THANK YOU FOR PURCHASING A WAPRO PRODUCT.
FOR FURTHER PRODUCT INFORMATION PLEASE REFER TO WAPRO.COM.**

INDEX

INTRODUCTION4
PREPARATION4
TERMINOLOGY5
OPENING PRESSURE 6
MAINTENANCE7
INSTALLATION WITH MOUNTING TABS - OUTLET 8-9
INSTALLATION WITH MOUNTING TABS - INLET10-11
INSTALLATION WITH FLANGE12-13
INSTALLATION INSIDE PIPE - MOUNTING TABS14-15
INSTALLATION INSIDE PIPE - BOLT THROUGH BELL15
FLEXIBLE COUPLING INSTALLATION16
PVC INLINE INSTALLATION17-18
GUARANTEE19-38

SERIAL NUMBER:

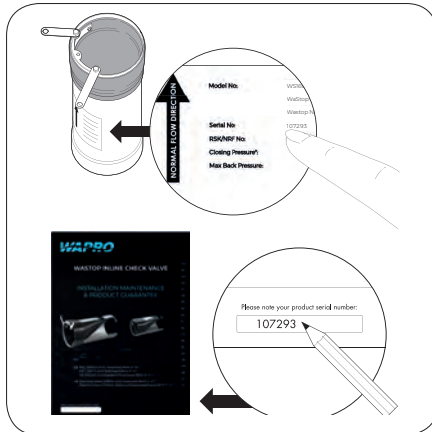

CE CERTIFIED: SS-EN-13564 -1:2002 TYPE O
US PATENT NO. 6,810,914, PCT/SE00/02524

INTRODUCTION

The following installation guide is designed to provide installers with sufficient information to successfully install a WaStop check valve. Typically, our customers were provided with shop drawings prior to manufacture for both review and authorization to manufacture. These documents alone, however, may not provide all the guidance needed to install the WaStop.

WASTOP INLINE CHECK VALVE

Regardless of dimension, all WaStop share some specific features. There are two main methods of installing a WaStop; with mounting tabs and rubber seal or with a flange. The dimension of the bolt holes is noted on the shop drawings.

ORIENTATION

The WaStop should always be installed with the 'spine' of the membrane upwards. Depending on the dimension the WaStop could be pushed in place by hand or using lifting equipment and slings.

FASTENER

Wapro recommends the use of concrete anchor bolts or threaded rods secured with chemical anchors. Different applications might warrant other fasteners.

SEALANT

A rubber seal is provided with all WaStops designed to be installed using mounting tabs. Damaged, out of round or otherwise irregular pipes might require additional sealing material such as hydrophilic systems; swellable profiles or sealants such as SikaSwell to fill minor cracks. WaStop with flange does generally not include any seal or gasket due to the variation of sealants different installations require.

- If the concrete has minor irregularities: hydrophilic systems; swellable profiles or sealants such as SikaSwell are recommended to fill minor cracks.
- If the concrete has cracks or irregularities, a non-shrinking grout is recommended to fill the voids between the sealing area and the concrete wall/pipe.
- For flange installations: If the concrete wall is in good shape with no cracks, flush and otherwise not damaged it's usually enough with EPDM tape, silicone sealant or similar attached to the flange to seal between the flange and the concrete mounting surface.

OVALITY

If the existing pipe is slightly out of round, it is possible to 'form' the WaStop to fit into the pipe. See drawings for more information.

PREPARATION

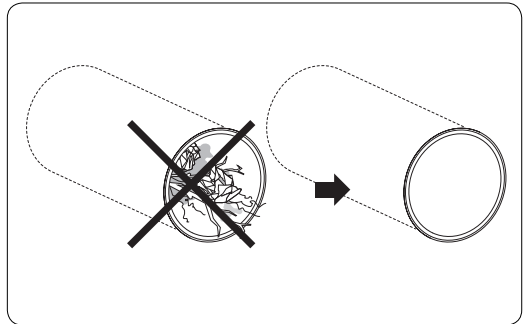
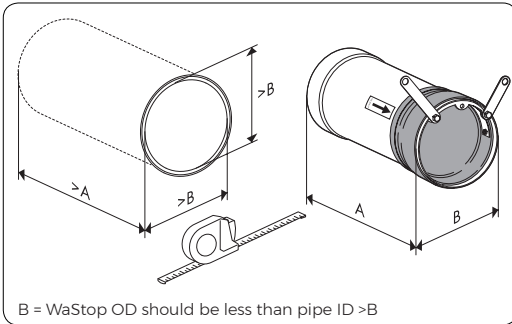

TERMINOLOGY

1. Flow direction. Flussrichtung. Sens d'écoulement. Dirección del Flujo. Sentido do fluxo. Flödesriktning. Virtausuunta. Flowretning. Strømeretning. Direzione del flusso. Stromingsrichtung. W kierunku przepływu. Voolu suund. Srauto kryptis. Plūsmas virziens. Směr toku. Áramlási irány. Smjer protoka tekućine. اتجاه التدفق. כיוון זרימה. צינור יציאה .
Existing pipe. Bestehendes Rohr. Conduite existante. Tubería existente. Tubo existente. Befintligt rör. Olemassaoleva putki. Eksisterende rør. Eksisterende rør. Tubazione esistente. Bestaande leiding. Istniejąca rura. Olemasolev toru. Esamas vamzdis. Esoša caurule. Stávající potrubí. Meglévo cso. Postojeća odvodna cijev. الأنبوب المتواجد. צינור יציאה .
2. Flexible coupling. Rohrkupplung. Manchon souple. Junta de acoplamiento. Acoplamento de União. Flexibel koppling. Liitos liitin. Kobling. Flexkobling. Giunto di collegamento. Koppelstuk. Złącze. Elastne ühendus. Sujungimo mova. Elastigā uzmava. Spojovací příruba. Kapcsolóféj. Spojnica. رابط مرن. צימוד גמיש.
3. Rubber seal. Gummidichtung. Joint caoutchouc. Junta de sellado. Vedação de borracha. Gummitätning. Kumi tiiviste. Gummi pakning. Gummipakning. Guarnizione. Rubberen afdichting. Gumova uszczelka. Kummitihend. Guminis sandariklis. Gumijas blīve. Gumové těsnění. Gumitömítés. Gumeni prsten. مانع تسريب. אטם גומי. مطاطي.
4. Head wall/chamber. Schachtwand. Paroi de regard. Pared de arqueta. Muro da câmara. Vægg/brunn. Kaivon seinä/Altaan seinä. Kumvegg. Væg/brønd. Parete pozzetto. Wand/Putwand. Ściana studni. Откосная стенка. Mahuti või kambri sein. Kameros ar šulinio siena. Stěna jímky. Akna fal. Sahta / pričrsvni zid. الجدار/انبر. דופן קדמית/דופן התא.
5. Bolts. Bewegliche Metall-Lasche. Boulons. Pernos Metálicos. Parafusos. Bultar. Pultit. Bolter. Bolte. Ancoraggio. Bouten. Śruby. Poldid. Varžtai. Skrúves. Kotvy. Csavarok. Pričrsvni vijci. براغي صناعية. ברגים.
6. Mounting tabs. Flacheisen. Bride plate. Fleje Metálico. Ferro chato. Plattjärn. Kiinnitysrauta. Flattjern. Fladjern. Barra di ancoraggio. Platte anker. Kotwica. Teraslatt. Plieninis fiksavimo plokštelės. Slokšņdzelzs. Upevňovací prvek. Befogó acél lemez. Metalna pričrsvna ploščica. לוחית מתכת. صفحة معدنية.

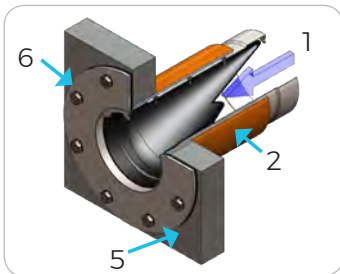
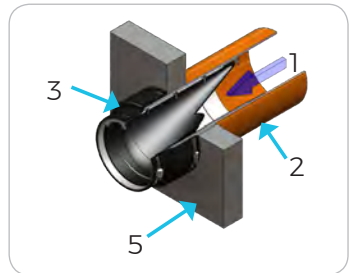
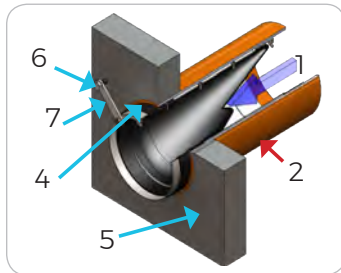
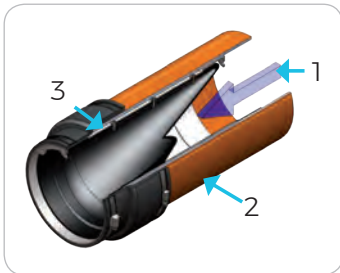

IMPORTANT: OPENING PRESSURE

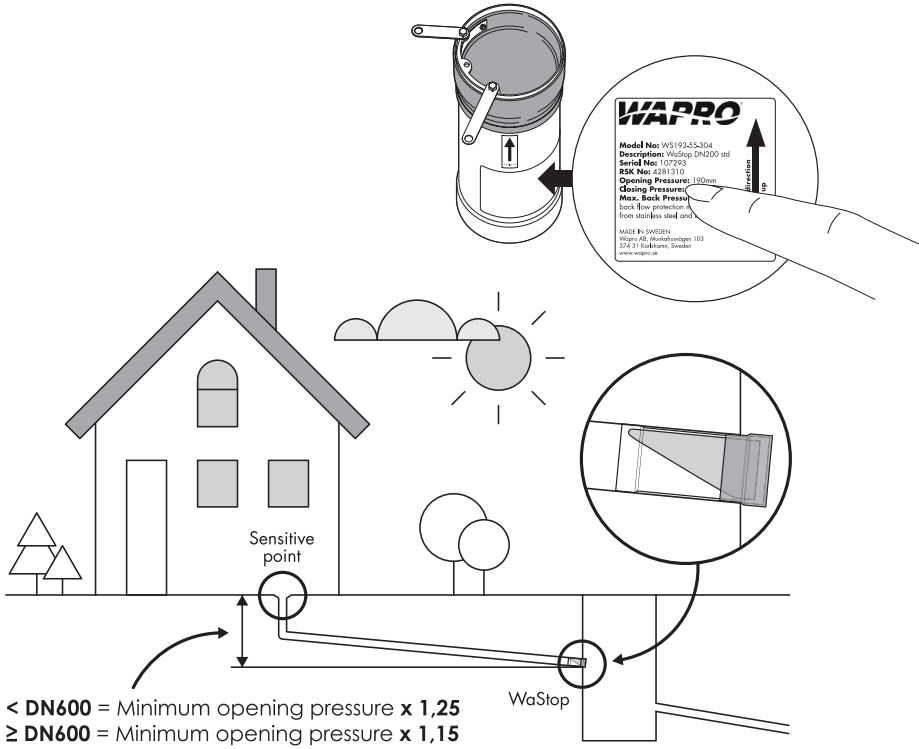

MAINTENANCE

The WaStop should occasionally be inspected for damage, wear, and debris.

The recommended frequency is twice per year but should be determined by the environment in which the valve operates.

FASTENERS

Check the bolts holding the mounting tabs, flange, flexible couplings or pipe to make sure they have not loosened during operation.

SEAL

Make sure the gasket or seal is in place and looks to be in good condition. Check also additional sealant if such has been used.

MARINE GROWTH

Soft marine growth is common in submerged and partly submerged applications and should be removed where possible. Do not use any sharp tools as this risks cutting the membrane. Hard marine growth such as barnacles do not bond well to the WaStop membrane and should be easy to remove with a plastic scraper or similar.

MEMBRANE

For smaller dimensions (<600mm / 24") the membrane should be exercised by hand. In larger dimensions the membrane is difficult to exercise by hand and therefore a visual inspection of the surface of the membrane is recommended. If there is any sign of debris upstream of the WaStop, the membrane should be opened with a crowbar or similar. Take caution not to damage the WaStop. Use only stainless steel tools to minimize the risk of contaminating the stainless steel.

If there is any damage to the valve, contact your WaStop supplier with product serial number, purchase date, photos and information about the installation conditions.



2 x/year or as required

INSTALLATION WITH MOUNTING TABS AND RUBBER SEAL

The rubber seal should be positioned halfway up the collar of the valve body, creating a step (diameter increase). When inserting the WaStop it should seal against the edge of the concrete pipe, see fig 4.

The mounting tabs are bolted to the concrete structure surrounding the host pipe, such as a wing wall or concrete chamber using the appropriate size fasteners.

In case of cracks or out of round pipes, there might be a need for additional sealant according to section 'Sealants' (page 4).

In the case of a protruding host pipe with no headwall, the mounting tabs can be bent back onto the pipe. In some cases, custom-made tabs may be required to be able to bolt the mounting tabs into the concrete pipe instead of a wall. Contact your Wapro representative for more information.

OUTLET INSTALLATION STAINLESS STEEL (INLET INTO CHAMBER)

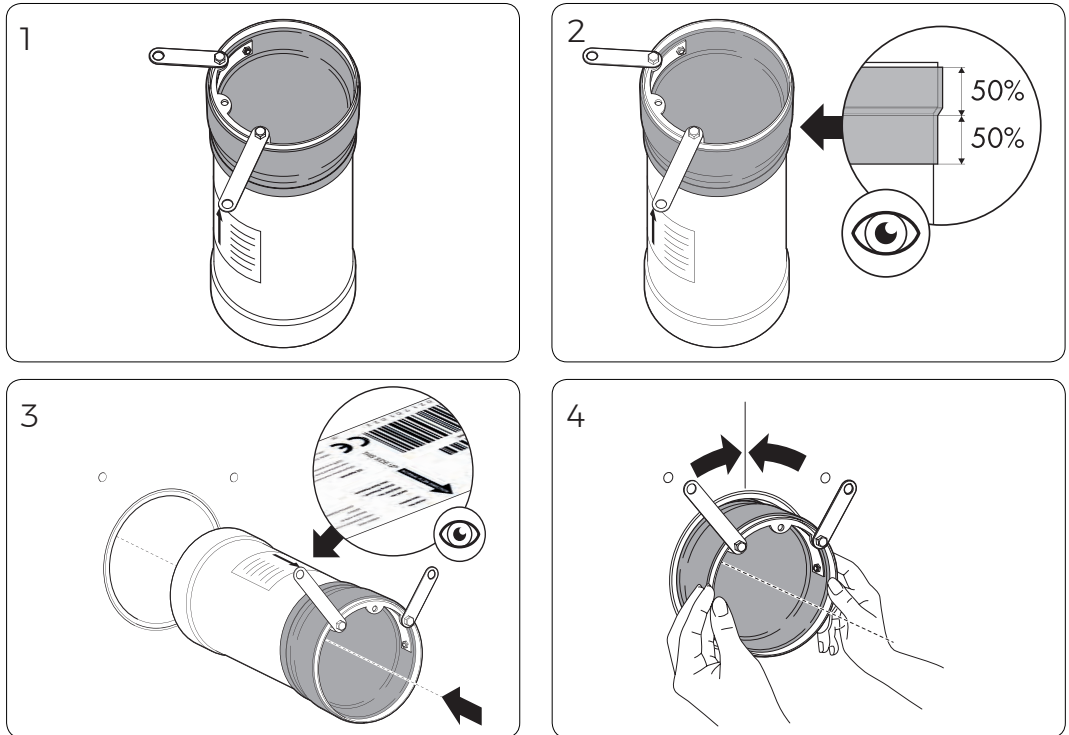

5

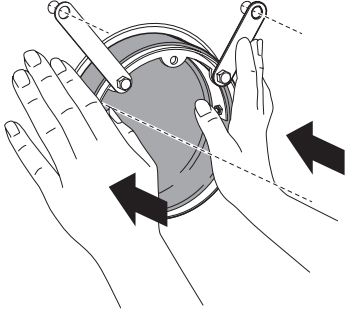

6

A4/316

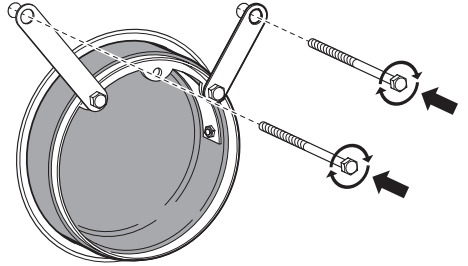

INSTALLATION WITH MOUNTING TABS AND RUBBER SEAL

The rubber seal should be positioned halfway up the collar of the valve body, creating a step (diameter increase). When inserting the WaStop it should seal against the edge of the concrete pipe, see fig 4.

The mounting tabs are bolted to the concrete structure surrounding the host pipe, such as a wing wall or concrete chamber using the appropriate size fasteners.

In case of cracks or out of round pipes, there might be a need for additional sealant according to section 'Sealants' (page 4).

In the case of a protruding host pipe with no headwall, the mounting tabs can be bent back onto the pipe. In some cases, custom-made tabs may be required to be able to bolt the mounting tabs into the concrete pipe instead of a wall. Contact your Wapro representative for more information.

INLET INSTALLATION STAINLESS STEEL (OUTLET FROM CHAMBER)

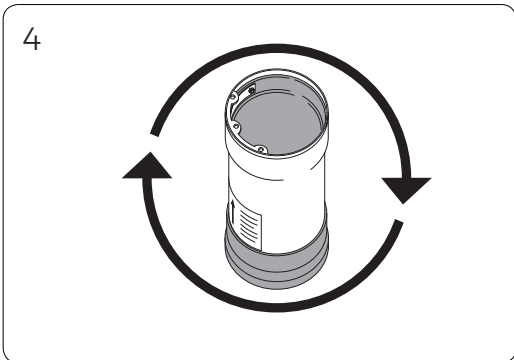
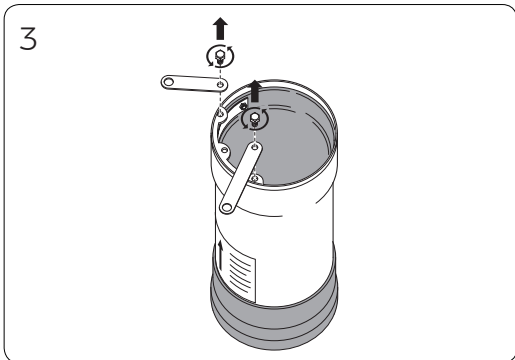
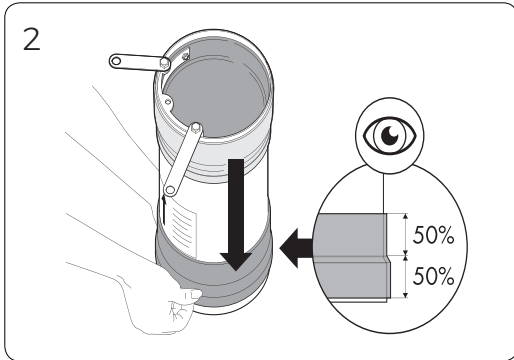
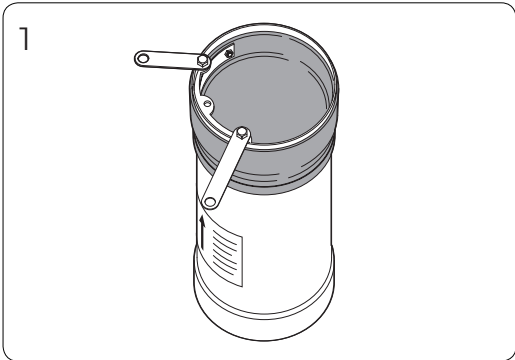

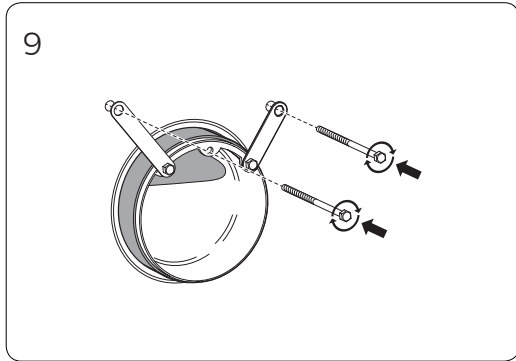
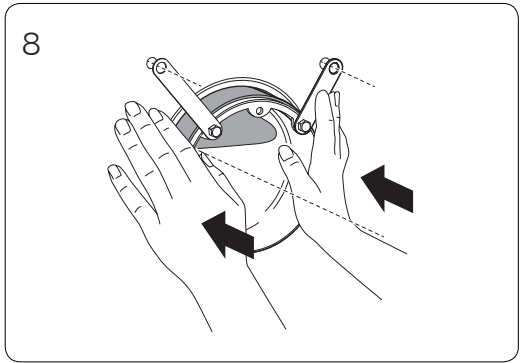
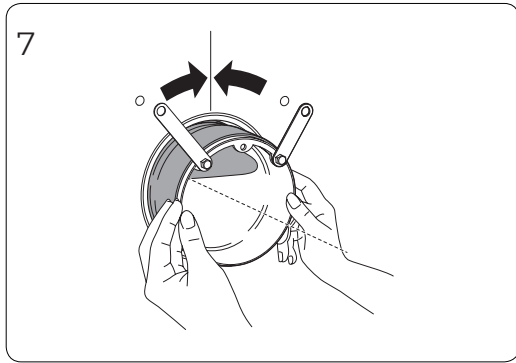
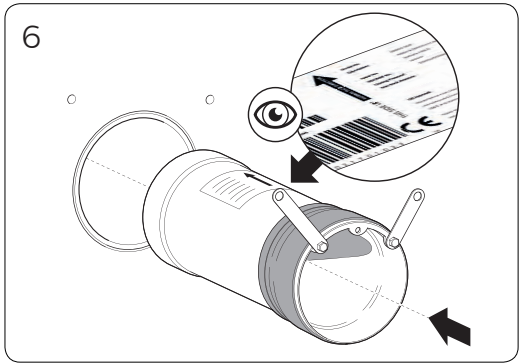
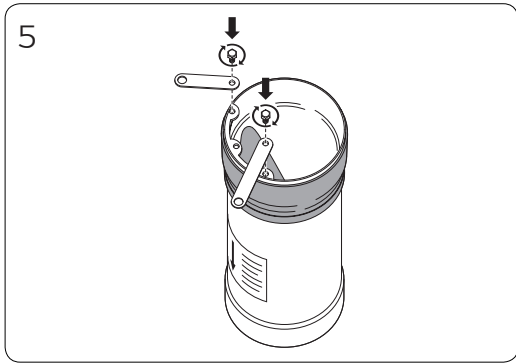

INSTALLATION WITH FLANGE - STAINLESS STEEL

Larger WaStops are installed with a flange. Once the host pipe is cleaned internally and inspected for irregularities, the following steps should be followed:

- ORIENTATION**
The WaStop should always be installed with the 'spine' of the membrane upwards
- POSITION**
The first step in installing a WaStop is to position the valve. Flange bolt holes are sized to allow anchor bolts to pass through the flange to the mounting surface.
- ANCHORS**
If threaded rod is used for anchors, install stainless steel threaded rods cut to appropriate length using a two-part epoxy-glue to secure the rods in the concrete. Allow time to set, according to the manufacturer's recommendation. Expansion anchors should be installed according to the manufacturers' recommendation.
- In the case of an irregular mounting surface, a thrust nut can be used to provide an adjustable surface against which the flange will rest. Adjust the nut leaving about 10mm (½") space between the flange and the mounting surface. In case of a flat surface, apply sealant and push flange firmly against the mounting surface.
- Place jam nut on each anchor, then firmly tighten jam nuts to secure the valve permanently.
- In case of voids between the mounting surface and the flange; mix a non-shrinking grout and fill the space between the mounting surface and the flange to seal.

RECOMMENDED SEALANT DEPENDS ON THE APPLICATION, GUIDELINES:

- If the concrete wall is in good shape with no cracks, flush and otherwise not damaged it's usually enough with EPDM tape, silicone sealant or similar attached to the flange to seal between the flange and the concrete mounting surface.
- If the concrete has minor irregularities: hydrophilic systems; swellable profiles or sealants such as SikaSwell are recommended to fill minor cracks.
- If the concrete has cracks or irregularities, a non-shrinking grout is recommended to fill the voids between the flange and the concrete wall.

FLANGE INSTALLATION STAINLESS STEEL

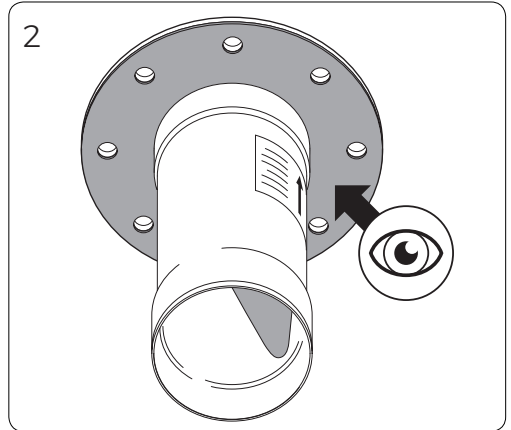
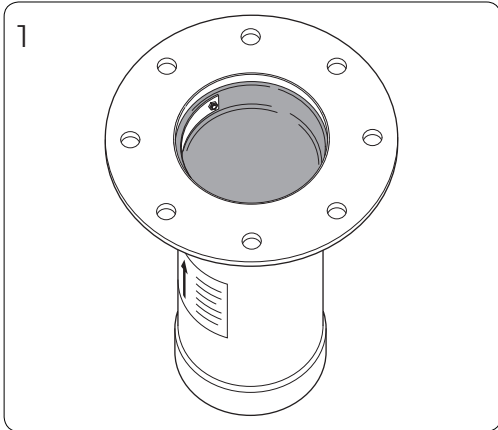

FLANGE INSTALLATION STAINLESS STEEL

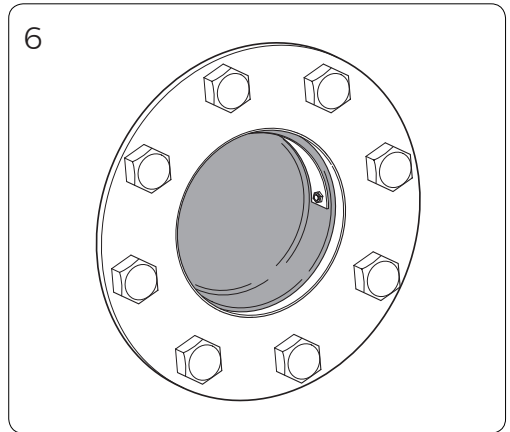
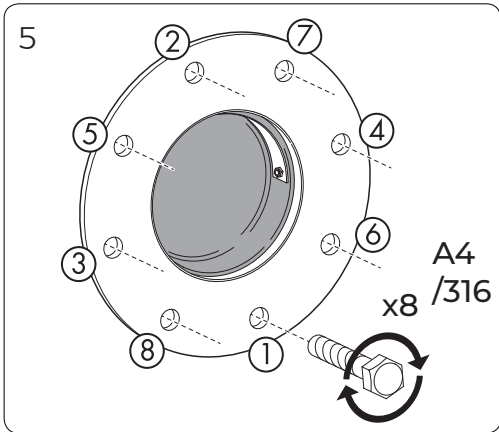
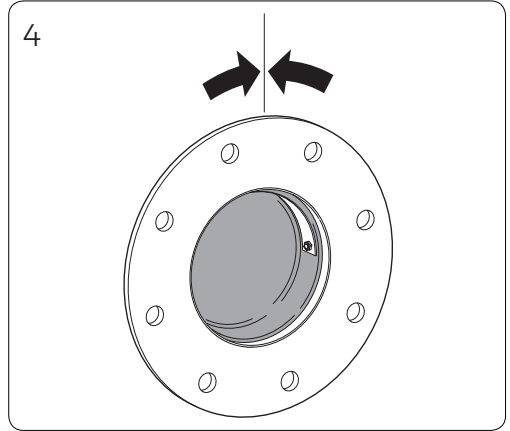
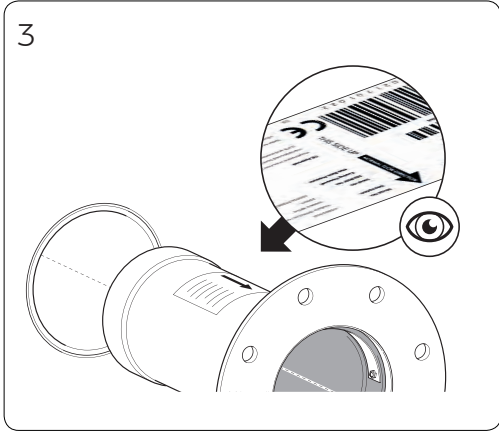

INSTALLATION INSIDE PIPE

ORIENTATION

The WaStop should always be installed with the 'spine' of the membrane upwards. Depending on the dimension the WaStop can be pushed in place by hand or using lifting equipment and slings.

FASTENER

Wapro recommends the use of concrete anchor bolts or threaded rods secured with chemical anchors. Bolt into the non-shrink grout, or concrete surrounding the WaStop valve body.

SEALANT

A WaStop secured by expansion bolts through the pre-drilled holes in the bell of the WaStop or custom made mounting tabs should be sealed by applying non-shrink grout between the inner diameter of the host pipe and the outer diameter of the WaStop valve body.

INSTALLATION

This section outlines the installation method when WaStop is sealed between the WaStop and the host pipe with non-shrinking grout and secured with concrete anchors. Grout and anchors are to be sourced locally. Manufacturers recommendations of these products should be followed.

Installation method:

1. Clean the inside of host pipe and inspect for irregularities.
2. Position the WaStop taking note of flow direction as well as 'this side up' as shown on the label of the WaStop.
3. Create a 20mm (1") space between the WaStop and the host pipe. Mix the non-shrink grout to a semi-solid to plastic consistency to ease application. Apply non-shrink grout underneath the WaStop then remove the spacers and fill the rest of the area around the WaStop. Allow the grout to set. It is recommended to form at least a 250mm (10") wide lining around the WaStop with grout.
4. Once the grout has set, secure the WaStop utilizing concrete anchor bolts.

INSTALLATION INSIDE PIPE - MOUNTING TABS

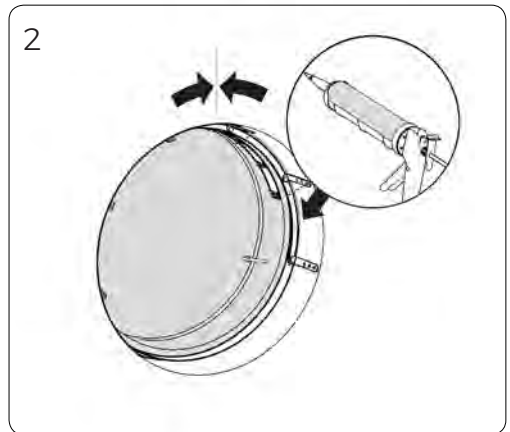
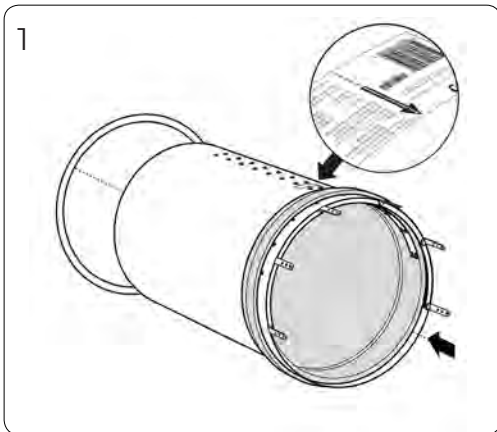

INSTALLATION INSIDE PIPE - MOUNTING TABS

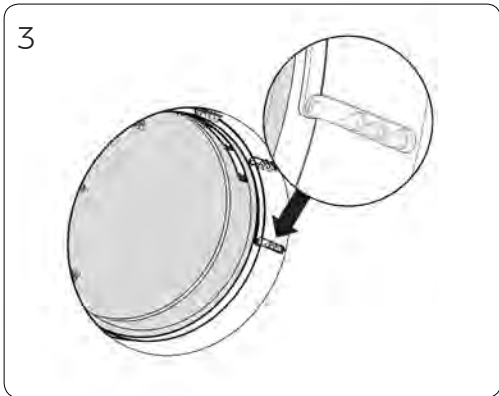

INSTALLATION INSIDE PIPE - BOLT THROUGH BELL

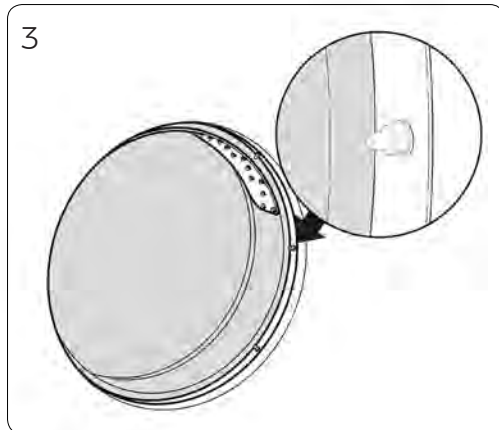
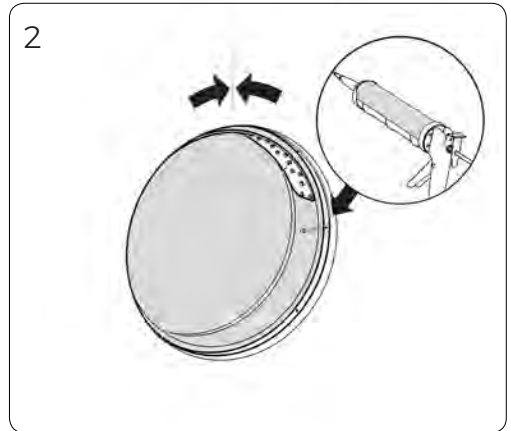
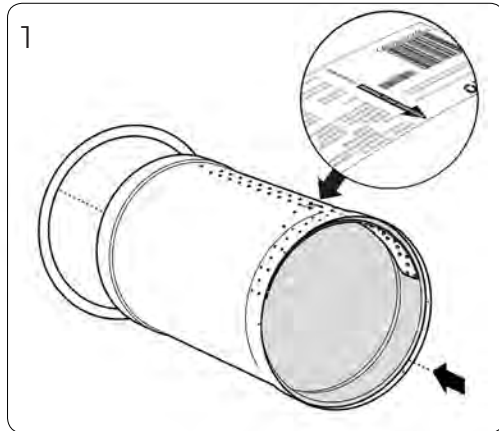

FLEXIBLE COUPLING INSTALLATION

1

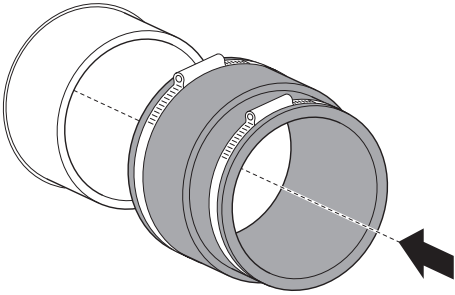

2

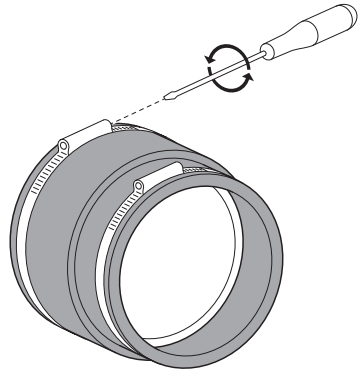

3

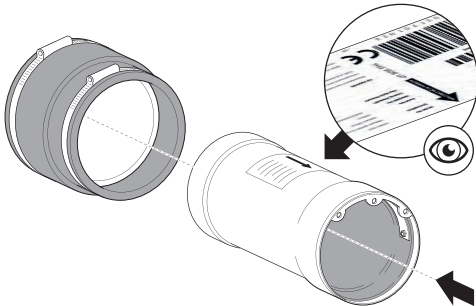

4

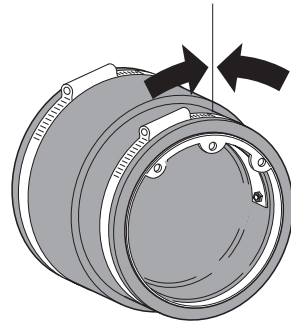

5

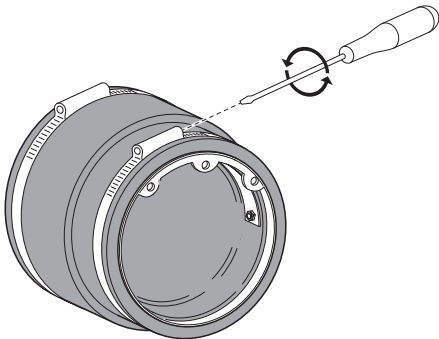

PVC INLINE INSTALLATION

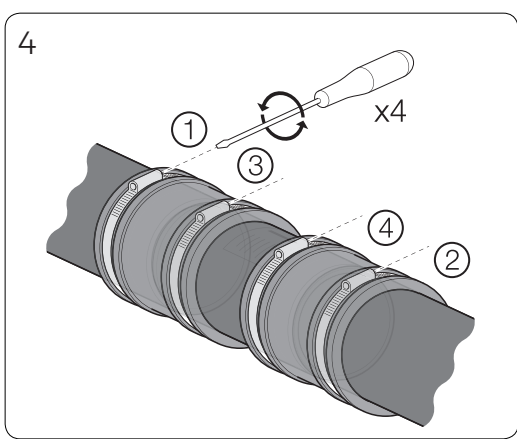
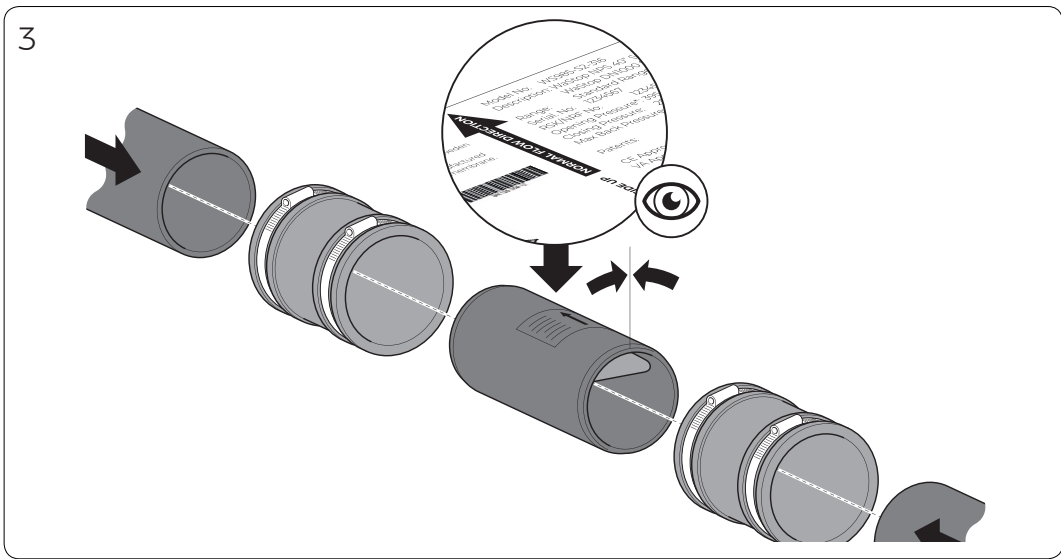
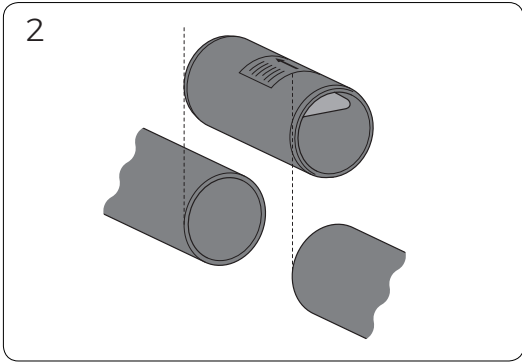
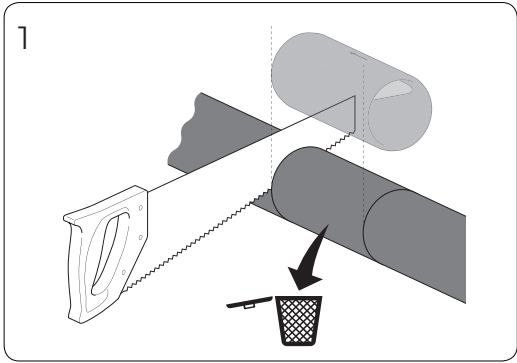

IMPORTANT: OPENING PRESSURE

DISTANCE BETWEEN THE LOWEST DRAINAGE POINT IN HOME TO BOTTOM OF WASTOP:

AT MINIMUM: $X \neq$ OPENING PRESSURE $\times 1,25$

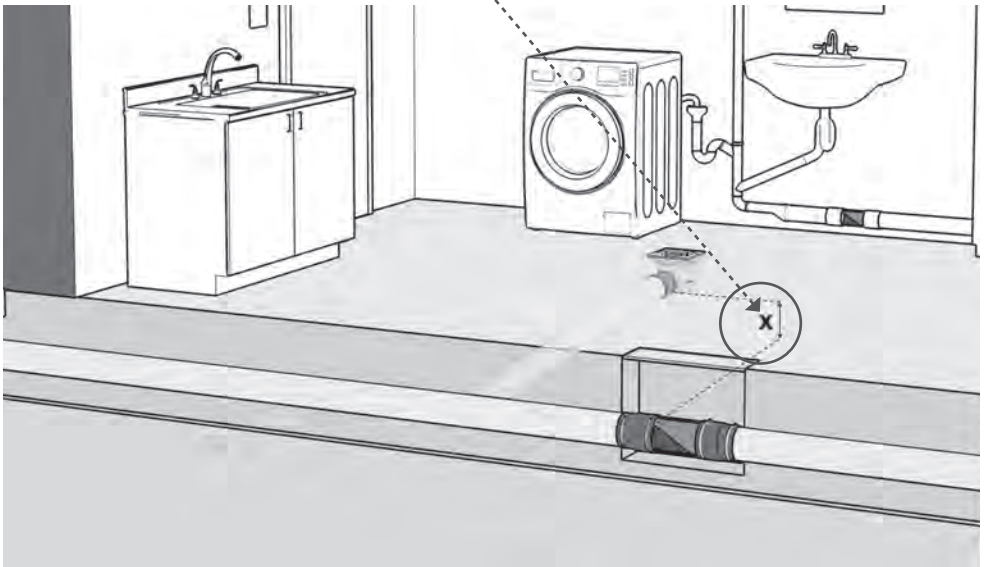
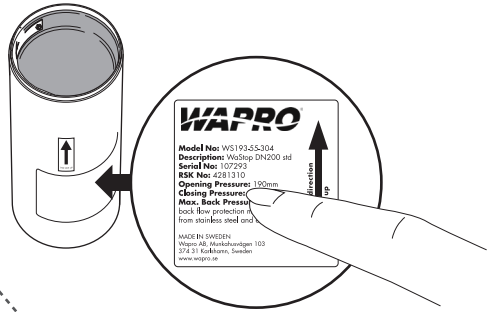

CONGRATULATIONS ON YOUR PURCHASE OF THE UNIQUE PATENTED WASTOP® INLINE CHECK VALVE

WaStop's unique construction prevents backflow in pipe networks. It can be installed in minutes either in existing pipes or manholes, and gives a reliable protection against high water levels, flotsam, gases, salt water, insects and small animals.

SAFETY FIRST

When installing a WaStop check valve please ensure that all safety precautions are taken. Wapro AB accepts no responsibility for incorrect installation or the improper use of this product. Incorrect installation can cause injury, reduce the valve lifetime or damage other mating pipe products. Please read the following information before installing the WaStop check valve. If you have any questions regarding installation please call your local WaStop reseller.

STORAGE

- The WaStop check valve should be stored in a cool dry location with good ventilation.
- The valves should not have anything inserted into either end touching the membrane during storage.
- Don't drop, put undue pressure upon, or twist the pipe or membrane as damage may occur.
- The smaller dimension valve should be stored in the box they were delivered in. Larger valves should be stored in a safe location where tampering cannot occur.
- Avoid unnecessary exposure to light and chemicals.
- Store all WaStop's in a vertical position with the end of the cone up. If this is not possible ensure the housing of the valve is supported to ensure ovality does not occur.

TERMINOLOGY

- Flow direction: Normal direction of flow
- Existing pipe: An existing pipe into which WaStop will be inserted.
- Joint coupling: A flexible coupling joining the existing pipe and the WaStop.
- Expansion bolt: A bolt having an attachment that expands as the bolt is driven into a surface.
- Rubber seal: A seal that ensures no leakage between the inside of the existing pipe and the WaStop.
- Back pressure: The fluid pressure exerted against the valve. Usually measured in feet or meters of fluid above the invert of the pipe.
- Membrane: The elastomer conical membrane inside the WaStop pipe.
- WaStop pipe: The outer casing (housing) of the WaStop membrane.

RECOMMENDATION

Wapro recommends strongly that the WaStop valve is accessible, that it is possible to un-install and remove the product without major structural damage or digging in the area surrounding the valve.

RECYCLING

WaStop primarily consists of environmentally friendly components. When disposing of the valve, disassemble and properly sort the parts for recycling. See table below for how the components are to be recycled.

	Stainless Steel**	PE*	PVC*	Silicone*	EDPM*	Polyurethane*
WaStop	Valve Body and fasteners	Valve Body	Valve body	Membrane	Membrane	Membrane

* Incinerate
 ** Metal recycling

WAPRO AB LIMITED WARRANTY

Wapro will remedy defects in material and/or workmanship in any new Wapro valve for a period of two (2) years from the documented date of purchase so long as the valve has been used in accordance with Wapro's instructions and recommendations and under normal operating conditions. The warranty does not cover damage to the valve caused by external mechanical forces, such as interference from humans, animals or machines, nor is the warranty valid if the valve has been modified or altered in any way post-production. Furthermore, the warranty is not valid (a) if the valve is damaged due to exposure to high concentrations of chemical substances, (b) if the valve is damaged due to pressure surges and/or vacuum within the valve, (c) the warranty is invalid if flow velocity exceeds 2m/s for WaStop <DN300, 3m/s for WaStop <DN500, 4m/s for WaStop <DN1050 and 5m/s for WaStop <DN1800, and (d) if malfunctions are caused by other equipment. A flange is required for flow velocity over 2m/s in all sizes. To request warranty service, the buyer should contact the WaStop dealer where the valve was purchased within a reasonable time after discovering any defects. The valve serial number must be quoted in the case of a warranty claim. Wapro's liability is limited to the replacement or repair of the defective valve. Wapro will not assume costs incurred for removal of defective valves or subsequent installation of replacement valves. Furthermore, Wapro will not assume transportation costs of damaged valves or replacement valves. Wapro warrants that repaired or replaced valves are covered for the greater of either the remainder of the original valve warranty or 90 days. THE WARRANTY EXPRESSED ABOVE SHALL BE IN LIEU OF ANY OTHER WARRANTIES, EXPRESSED OR IMPLIED, INCLUDING, WITHOUT LIMITATION, ANY IMPLIED WARRANTIES OR CONDITIONS OF MERCHANTABILITY, FITNESS FOR A PARTICULAR PURPOSE AND NON-INFRINGEMENT WHICH ARE EXPRESSLY DISCLAIMED, AND IS IN LIEU OF ANY AND ALL OTHER OBLIGATIONS OR LIABILITY ON WAPRO'S PART. TO THE MAXIMUM EXTENT PERMITTED BY APPLICABLE LAW, UNDER NO CIRCUMSTANCES WILL WAPRO BE LIABLE TO BUYER FOR ANY INDIRECT, INCIDENTAL, SPECIAL OR CONSEQUENTIAL DAMAGES (INCLUDING ANY DAMAGE FOR LOSS OF REVENUE OR PROFIT), OR OTHERWISE ARISING OUT OF OR IN CONNECTION WITH FURNISHING OF THE VALVES, PARTS OR SERVICE HEREUNDER, OR THE PERFORMANCE, USE OF, OR INABILITY TO USE ANY OF THE VALVES, PARTS OR SERVICE, OR OTHERWISE, WHETHER BASED IN CONTRACT, WARRANTY, TORT, INCLUDING WITHOUT LIMITATION, NEGLIGENCE OR ANY OTHER LEGAL OR EQUITABLE THEORY. TO THE MAXIMUM EXTENT PERMITTED BY APPLICABLE LAW, THE REMEDIES SET FORTH IN THIS LIMITED WARRANTY SHALL APPLY EVEN IF SUCH REMEDIES FAIL THEIR ESSENTIAL PURPOSE. FOR THE AVOIDANCE OF DOUBT, NO EMPLOYEE, AGENT OR OTHER REPRESENTATIVE OF WAPRO IS AUTHORIZED TO EXTEND OR OTHERWISE MODIFY THE WARRANTY SPECIFIED HEREIN.



HOLDING BACK THE FLOOD

Wapro solutions protect against stormwater and backflow flooding
Protecting people and property

Wapro AB
Munkahusvägen 103
SE-374 31 Karlshamn, Sweden
Tel: +46 454 185 10
Email: wapro@wapro.com

wapro.com